



ZERTIFIKAT
EQ
ZERT
ISO 9001

FORMSTECHSYSTEME

Schafthalter

Form Grooving Systems Systèmes de profilage en plongée

Shank Holder

Porte-plaquettes à manche

1



Otto Dieterle Spezialwerkzeuge GmbH

Predigerstr. 56, 78628 Rottweil, Germany

Tel.: +49(0) 741 94205-0 Fax: +49(0) 741 94205-50 info@dieterle-tools.com

www.dieterle-tools.com

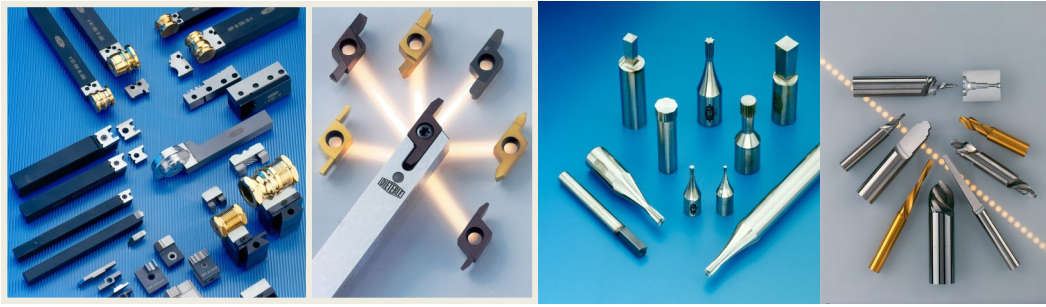

ZERTIFIKAT
EQ
 ZERT
 ISO 9001

Sehr geehrter Kunde,

Unser Spezialwissen im technischen Bereich der Drehteilfertigung ermöglicht es uns, Problemlösungen im Werkzeugbereich zu schaffen, welche außerhalb des üblichen Standards liegen. Wir sind überzeugt, dass vor allem die qualitative Leistung den Erfolg und die Stabilität eines Unternehmens im Wesentlichen beeinflusst.

Deshalb sehen wir unsere Aufgabe in der ständigen Neuorientierung der qualitativen und produktiven Anforderungen, mit welchen sich unsere Kunden auseinandersetzen müssen. Die Zielsetzung unserer Firma ist es, die Kunden durch die optimale Lösung ihrer fertigungstechnischen Probleme zum Erfolg zu verhelfen.

Dear user,

Our special knowledge in the technically advanced field of producing turned parts enables us to produce tooling solutions which are beyond typical standards. We are convinced that quality is the most important factor for the future prospects of every company in that market. This is why we are always searching for new solutions to solve new problems of our customers. It is our aim to help our customers succeed in their market through supplying best solutions for their manufacturing problems.

Cher utilisateur,

Nos spéciales expériences dans le domaine technique de la fabrication des pièces tournées nous permet de fournir des solutions aux problèmes dans le domaine de l'outil, qui se trouvent en dehors des normes habituelles. Nous pensons que, en particulier la performance qualitative affecte le succès et la stabilité d'une société essentiellement, et nous voyons notre tâche dans la réorientation continue des besoins qualitatifs et productifs dont nos clients ont besoin. L'objectif de notre société est d'aider les clients à trouver la solution optimale de ses problèmes techniques.

Die Angaben in diesem Katalog und der dazugehörigen Preisliste entsprechen dem Stand zu Druckbeginn. Eventuelle Änderungen oder Druckfehler berechtigen nicht zu Ansprüchen. Mit Erscheinen dieses Kataloges werden alle entsprechenden vorherigen Kataloge ungültig. Nachdruck von Text und Bildern, auch auszugsweise, ist ohne unsere Genehmigung nicht gestattet.

All details in this catalogue and the corresponding price list are in accordance with our current standards at the time of printing. Any modifications, changes or misprints do not entitle to damages or claims. With the publication of this catalogue any other existing catalogue is void. No text, photograph and drawing, even in the form of extracts, may be reprinted without our permission.

Les indications de ce catalogue correspondent à la situation actuelle. Les modifications intervenues ou éventuelles erreurs d'impression n'ouvrent pas droit à des prétentions quelqu'elles soient. Toutes les autres catalogues sont rendues caduques par la parution de celui-ci. La reproduction de textes et d'images, même partielle, est interdite sans notre autorisation.

Stand / Version 04/2017

System / Système

ANF

Seite / Page:

7-15

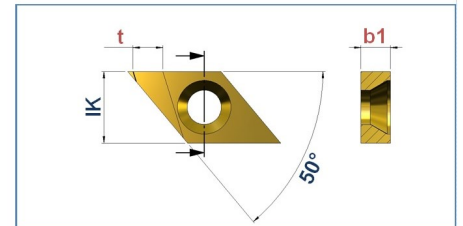
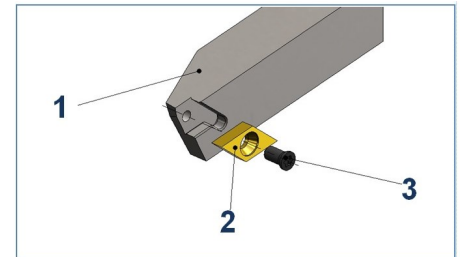
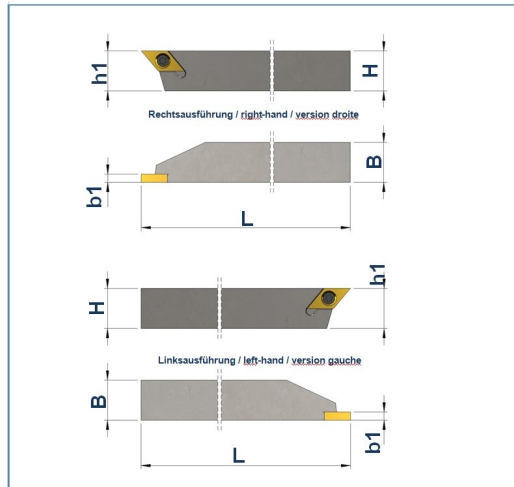

Werkzeughalter mit Innenkühlmittelzufuhr möglich

Tool holders with internal coolant supply possible / Porte-outils avec des conduits d'arrosage internes possible

System / Système

TreAngoli

Seite / Page:

16-20

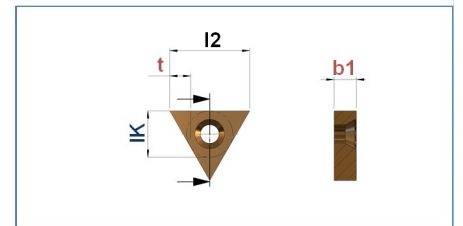
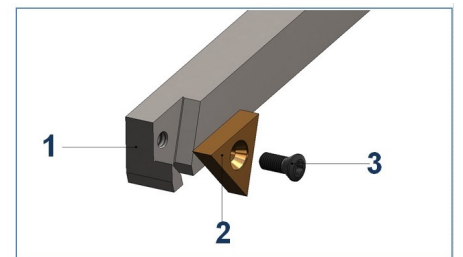
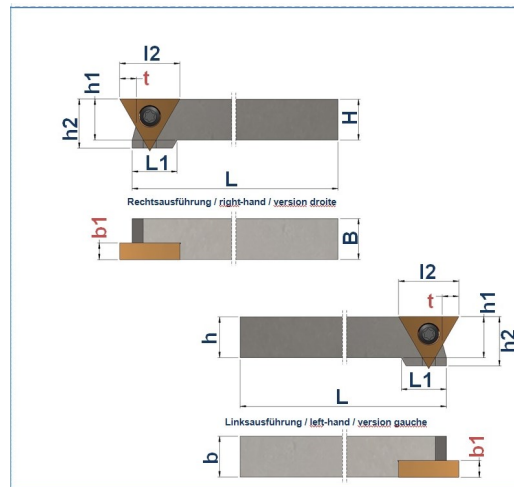

Werkzeughalter mit Innenkühlmittelzufuhr möglich

Tool holders with internal coolant supply possible / Porte-outils avec des conduits d'arrosage internes possible

System / Système

FHGU-ES

Seite / Page:

21-22

neu / new / nouveau

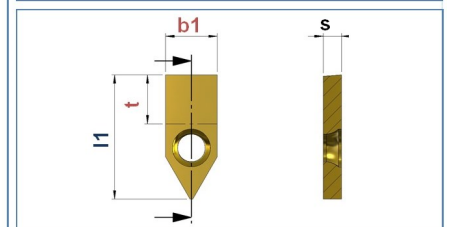
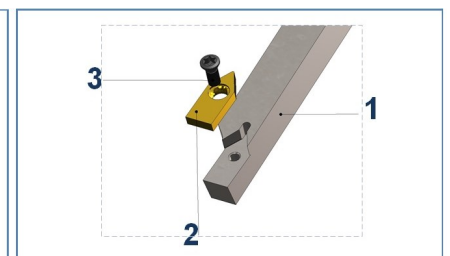
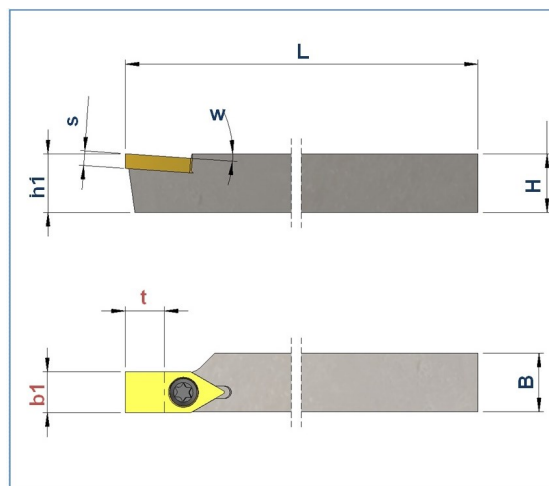

Werkzeughalter mit Innenkühlmittelzufuhr möglich

Tool holders with internal coolant supply possible / Porte-outils avec des conduits d'arrosage internes possible

System / Système H-TFP

Seite / Page:

23

neu / new / nouveau

Eine Platte für große Stechtiefen
 An insert for large penetration depth
 Une plaquette pour la grande profondeur d'usinage

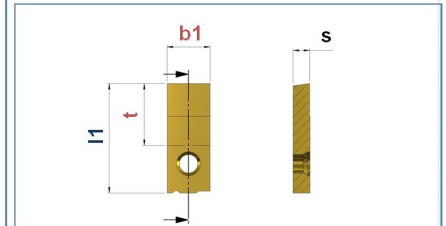
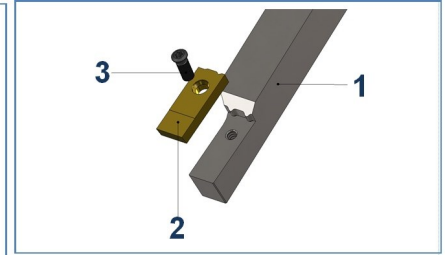
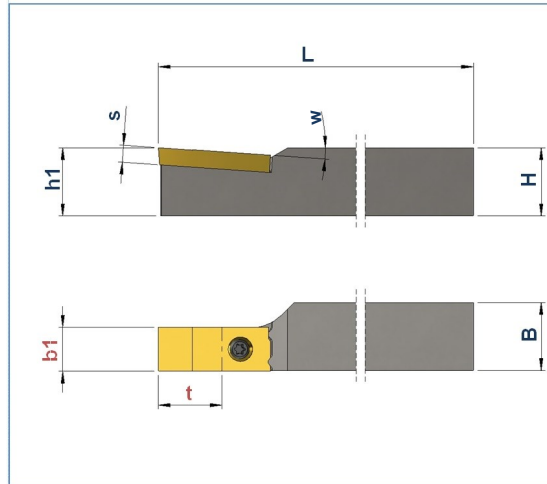

Werkzeughalter mit Innenkühlmittelzufuhr möglich

Tool Holders with Internal Coolant Supply possible / Porte-outils avec des conduits d'arrosage internes possible

System / Système FHFPN

Seite / Page:

24-29

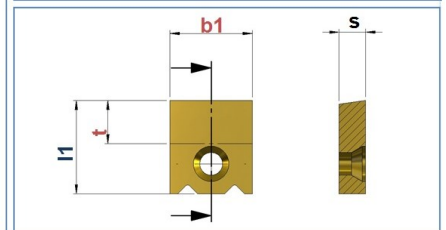
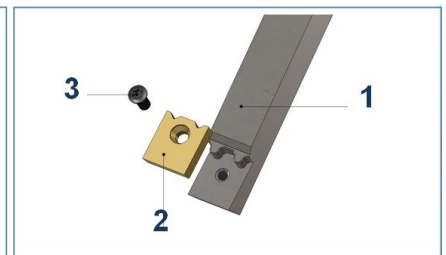
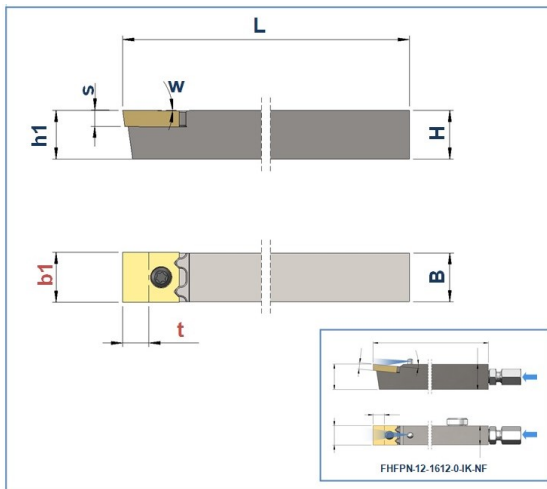

Werkzeughalter mit Innenkühlmittelzufuhr möglich

Tool holders with internal coolant supply possible / Porte-outils avec des conduits d'arrosage internes possible

System / Système FHFP/FHEB

Seite / Page:

30-40

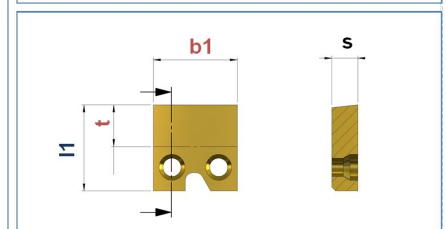
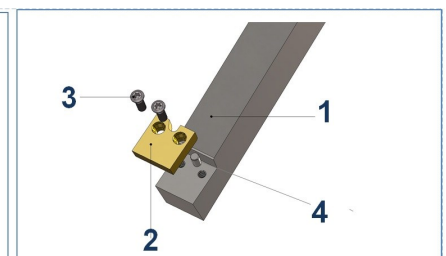
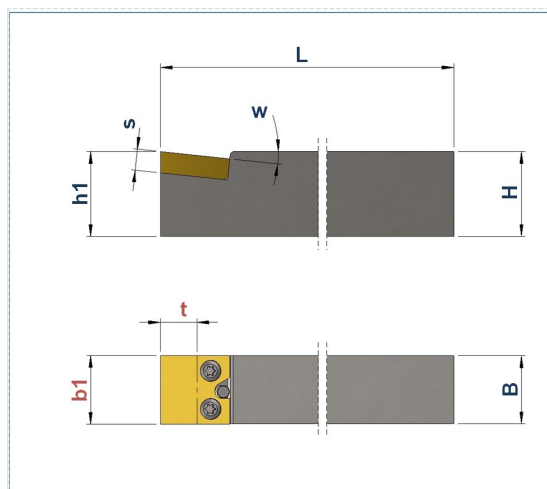

Werkzeughalter mit Innenkühlmittelzufuhr möglich

Tool Holders with Internal Coolant Supply possible / Porte-outils avec des conduits d'arrosage internes possible

System / Système FHFPT

Seite / Page:
41-43

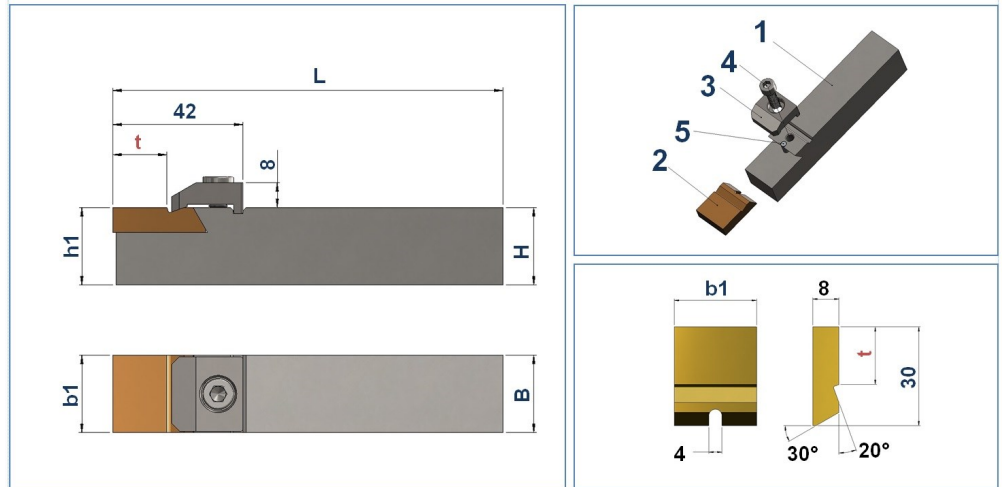

Werkzeughalter mit Innenkühlmittelzufuhr möglich
 Tool holders with internal coolant supply possible / Porte-outils avec des conduits d'arrosage internes possible

System / Système F-BFH

Seite / Page:
44-49

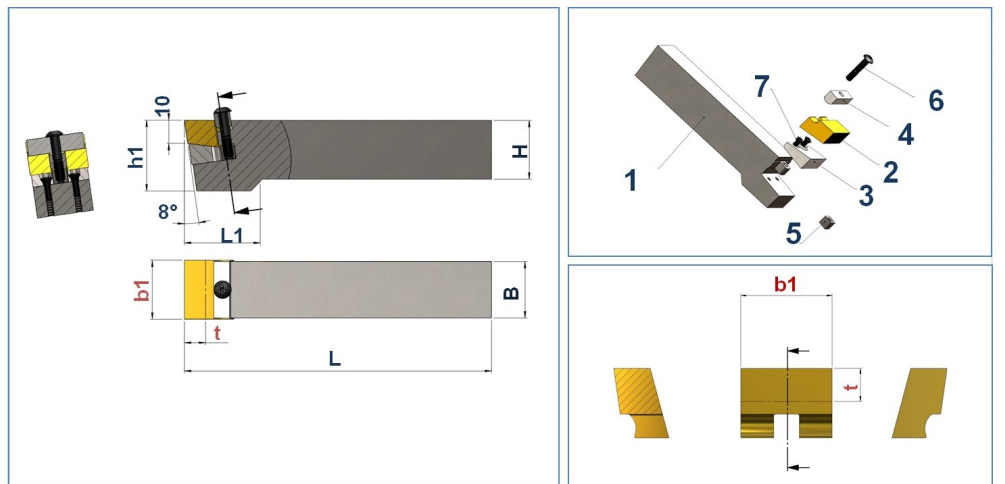

Werkzeughalter mit Innenkühlmittelzufuhr möglich
 Tool holders with internal coolant supply possible / Porte-outils avec des conduits d'arrosage internes possible

System / Système SH-258

Seite / Page:
50

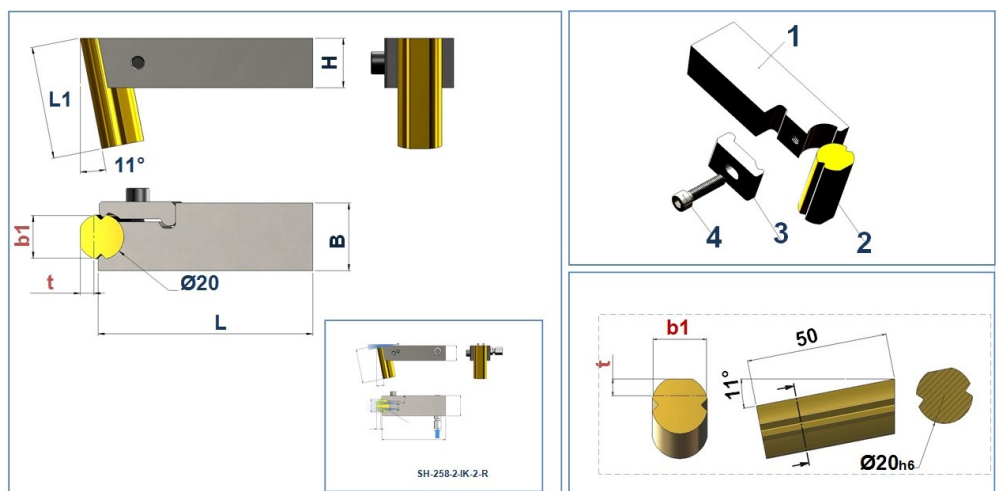

Werkzeughalter mit Innenkühlmittelzufuhr möglich
 Tool holders with internal coolant supply possible / Porte-outils avec des conduits d'arrosage internes possible

System / Système SSXA

Seite / Page:
51

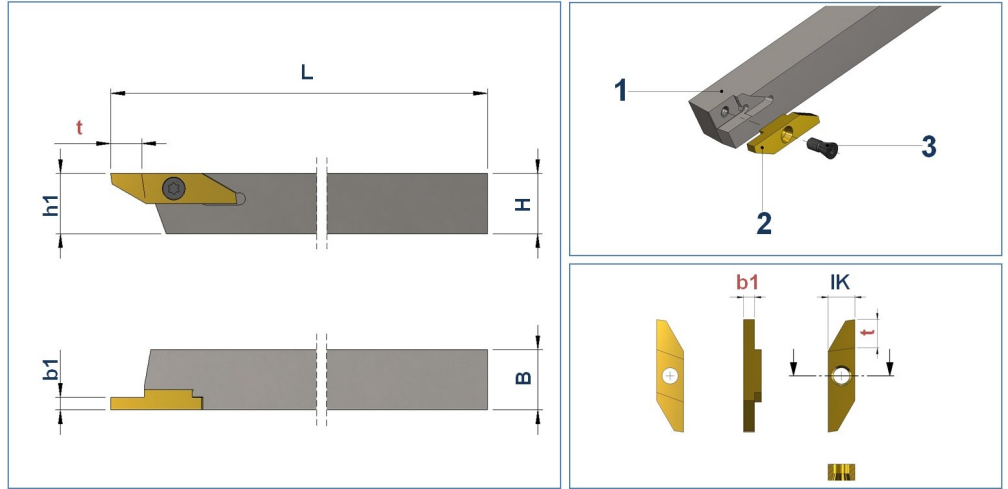

Werkzeughalter mit Innenkühlmittelzufuhr möglich
 Tool holders with internal coolant supply possible / Porte-outils avec des conduits d'arrosage internes possible

System / Système SSXC

Seite / Page:
52

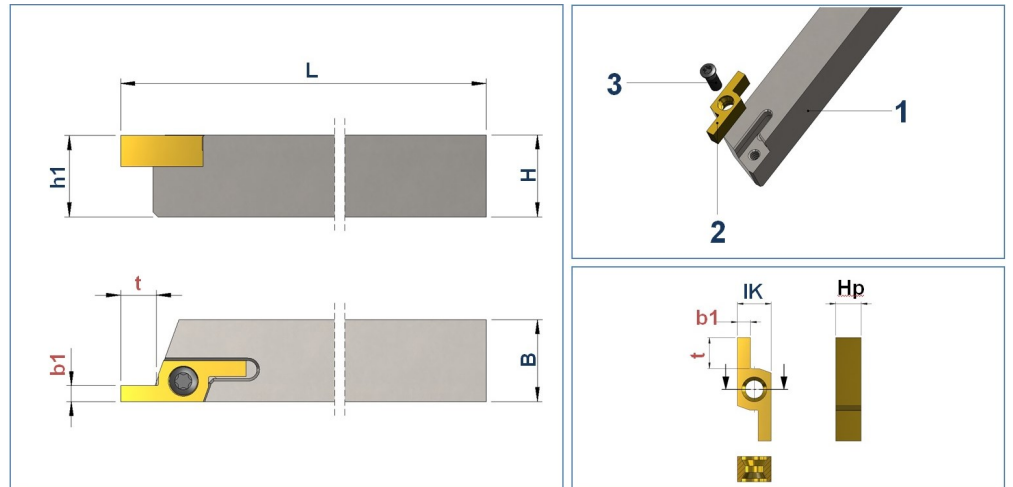

Werkzeughalter mit Innenkühlmittelzufuhr möglich
 Tool holders with internal coolant supply possible / Porte-outils avec des conduits d'arrosage internes possible

System / Système EcoStar

Seite / Page:
53

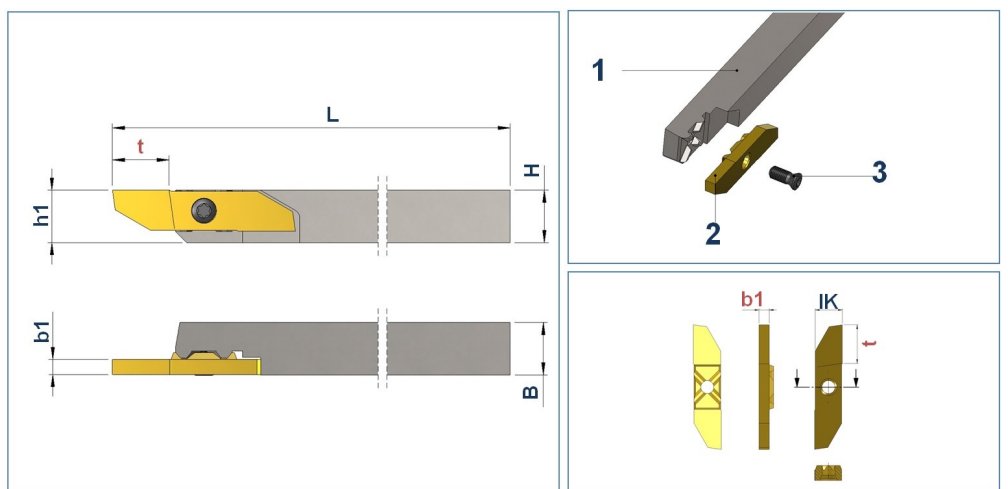

Werkzeughalter mit Innenkühlmittelzufuhr möglich
 Tool holders with internal coolant supply possible / Porte-outils avec des conduits d'arrosage internes possible

Seite / Page:
54

Nachschleifvorrichtungen

Device for regrinding carbide inserts

Dispositif pour l'affutage des plaquettes en carbure

ANF-07...R / L

max. Formtiefe: **t = 2.5 mm**
 max. depth of form: **t = 2.5 mm**
 max. profondeur de profil: **t = 2.5 mm**

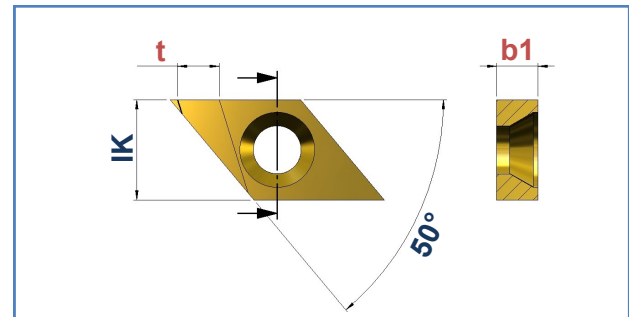
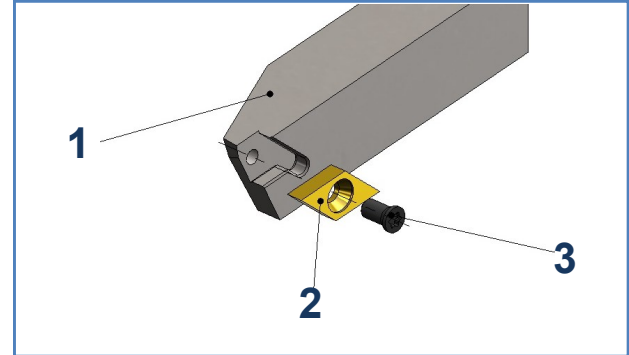
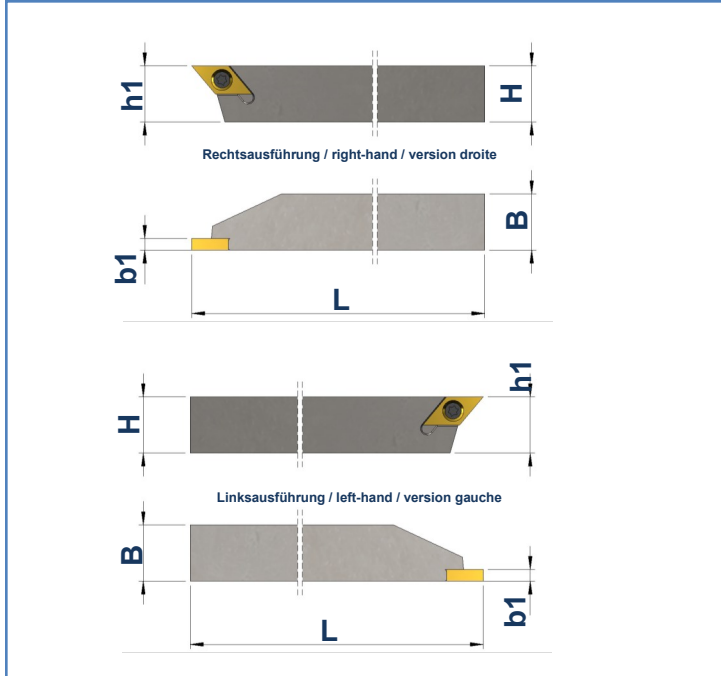

1	Art. Nr. Item no. No. d'art.	Best. Nr. Ref. no. Réf.	Bezeichnung description désignation	B mm	H mm	b1 mm	h1 mm	L mm
	100394	ANF-07-0808-R	Halter / Basic tool holder / Porte-outil de base	8	8	2,5	8	141
100396	ANF-07-1010-R	Halter / Basic tool holder / Porte-outil de base	10	10	2,5	10	141	
100398	ANF-07-1212-R	Halter / Basic tool holder / Porte-outil de base	12	12	2,5	12	141	
108735	ANF-07-1616-R	Halter / Basic tool holder / Porte-outil de base	16	16	2,5	16	126	
152237	ANF-07-2525-R	Halter / Basic tool holder / Porte-outil de base	25	25	2,5	25	126	
100393	ANF-07-0808-L	Halter / Basic tool holder / Porte-outil de base	8	8	2,5	8	141	
100395	ANF-07-1010-L	Halter / Basic tool holder / Porte-outil de base	10	10	2,5	10	141	
100397	ANF-07-1212-L	Halter / Basic tool holder / Porte-outil de base	12	12	2,5	12	141	
155659	ANF-07-1616-L	Halter / Basic tool holder / Porte-outil de base	16	16	2,5	16	126	
157561	ANF-07-2020-L	Halter / Basic tool holder / Porte-outil de base	20	20	2,5	25	126	
152238	ANF-07-2525-L	Halter / Basic tool holder / Porte-outil de base	25	25	2,5	25	126	

2	Art. Nr. Item no. No. d'art.	Best. Nr. Ref. no. Réf.	Bezeichnung description désignation	b1 mm	IK mm	HM-Sorte Carbide grade Nuance de carbure
	100960	FS-07-250-UG-N-G1A-FK	HM-Wendeplatten / Carbide inserts / Plaquettes réversibles	2,5	6,0	FK
100961	FS-07-250-UG-N-G1A-K10	HM-Wendeplatten / Carbide inserts / Plaquettes réversibles	2,5	6,0	K10	

3	Art. Nr. Item no. No. d'art.	Best. Nr. Ref. no. Réf.	Bezeichnung description désignation
	102608	Torx S-253545-T7	Spannschraube / Fixing screw / Vis de fixation

ANF-07-3...R / L

max. Formtiefe: **t = 2.5 mm**
 max. depth of form: **t = 2.5 mm**
 max. profondeur de profil: **t = 2.5 mm**

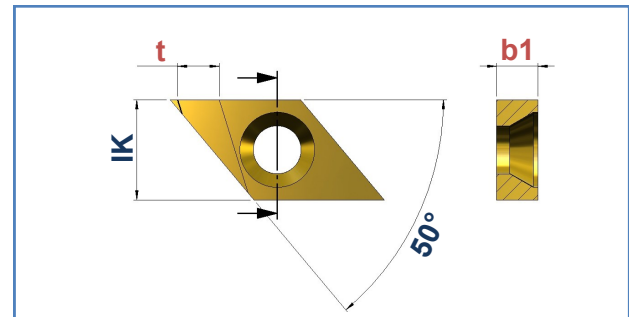
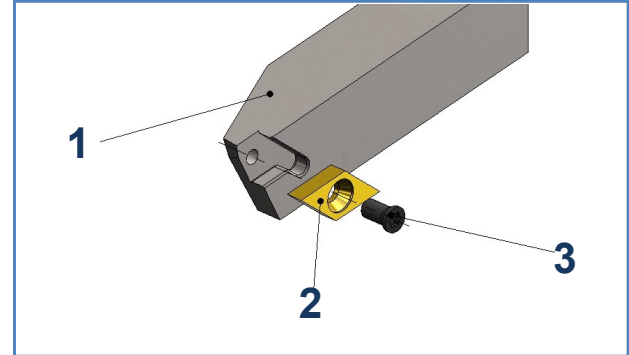
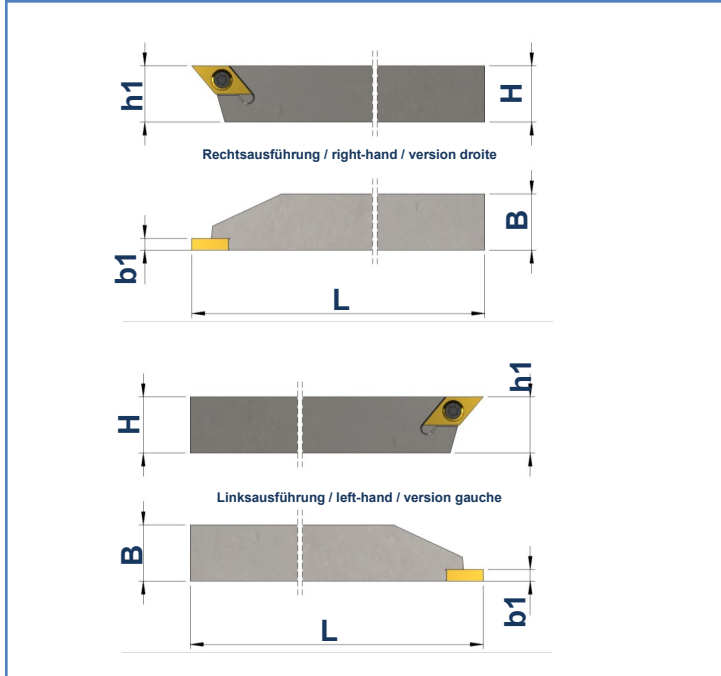

1	Art. Nr. Item no. No. d'art.	Best. Nr. Ref. no. Réf.	Bezeichnung description désignation	B mm	H mm	b1 mm	h1 mm	L mm
	141680	ANF-07-3-0808-R	Halter / Basic tool holder / Porte-outil de base	8	8	3,0	8	141
165802	ANF-07-3-1010-R	Halter / Basic tool holder / Porte-outil de base	10	10	3,0	10	141	
165803	ANF-07-3-1212-R	Halter / Basic tool holder / Porte-outil de base	12	12	3,0	12	141	
165804	ANF-07-3-1616-R	Halter / Basic tool holder / Porte-outil de base	16	16	3,0	16	126	
134815	ANF-07-3-0808-L	Halter / Basic tool holder / Porte-outil de base	8	8	3,0	8	141	
165805	ANF-07-3-1010-L	Halter / Basic tool holder / Porte-outil de base	10	10	3,0	10	141	
165806	ANF-07-3-1212-L	Halter / Basic tool holder / Porte-outil de base	12	12	3,0	12	141	
165807	ANF-07-3-1616-L	Halter / Basic tool holder / Porte-outil de base	16	16	3,0	12	141	

2	Art. Nr. Item no. No. d'art.	Best. Nr. Ref. no. Réf.	Bezeichnung description désignation	b1 mm	IK mm	HM-Sorte Carbide grade Nuance de carbure
	100969	FS-07-300-UG-N-G1A-FK	HM-Wendeplatten / Carbide inserts / Plaquettes réversibles	3,0	6,0	FK
100970	FS-07-300-UG-N-G1A-K10	HM-Wendeplatten / Carbide inserts / Plaquettes réversibles	3,0	6,0	K10	

3	Art. Nr. Item no. No. d'art.	Best. Nr. Ref. no. Réf.	Bezeichnung description désignation
	102206	Torx M2,5x7,2-T7	Spannschraube / Fixing screw / Vis de fixation

ANF-07-4...R / L

max. Formtiefe: **t = 2.5 mm**
 max. depth of form: **t = 2.5 mm**
 max. profondeur de profil: **t = 2.5 mm**

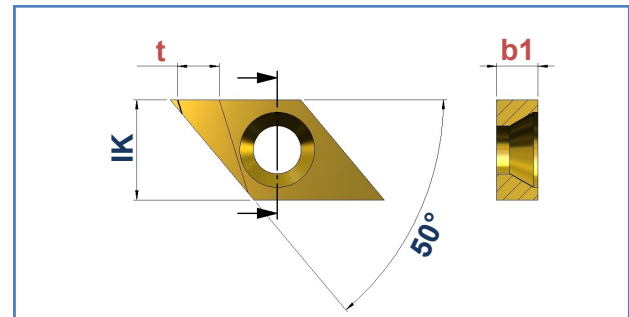
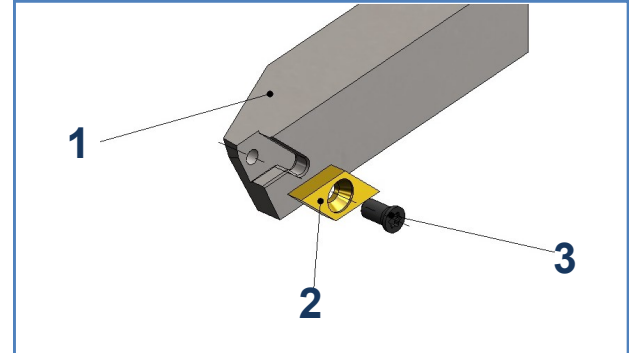
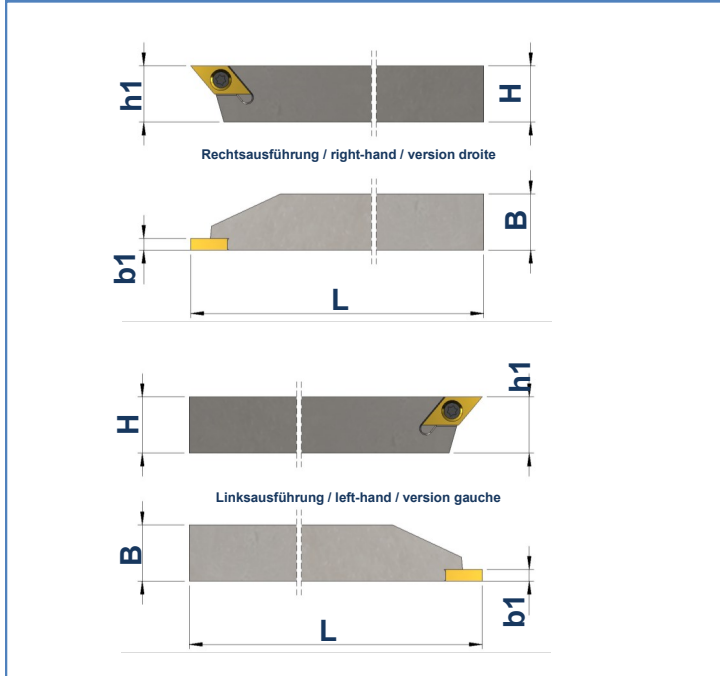

1	Art. Nr. Item no. No. d'art.	Best. Nr. Ref. no. Réf.	Bezeichnung description désignation	B mm	H mm	b1 mm	h1 mm	L mm
	100388	ANF-07-4-0808-R	Halter / Basic tool holder / Porte-outil de base	8	8	4,0	8	141
100390	ANF-07-4-1010-R	Halter / Basic tool holder / Porte-outil de base	10	10	4,0	10	141	
100392	ANF-07-4-1212-R	Halter / Basic tool holder / Porte-outil de base	12	12	4,0	12	141	
141403	ANF-07-4-1616-R	Halter / Basic tool holder / Porte-outil de base	16	16	4,0	16	126	
100387	ANF-07-4-0808-L	Halter / Basic tool holder / Porte-outil de base	8	8	4,0	8	141	
100389	ANF-07-4-1010-L	Halter / Basic tool holder / Porte-outil de base	10	10	4,0	10	141	
100391	ANF-07-4-1212-L	Halter / Basic tool holder / Porte-outil de base	12	12	4,0	12	141	
165809	ANF-07-4-1616-L	Halter / Basic tool holder / Porte-outil de base	16	16	4,0	12	141	

2	Art. Nr. Item no. No. d'art.	Best. Nr. Ref. no. Réf.	Bezeichnung description désignation	b1 mm	IK mm	HM-Sorte Carbide grade Nuance de carbure
	100979	FS-07-400-UG-N-G1A-K10	HM-Wendeplatten / Carbide inserts / Plaquettes réversibles	4,0	6,0	K10

3	Art. Nr. Item no. No. d'art.	Best. Nr. Ref. no. Réf.	Bezeichnung description désignation
	102206	Torx M2,5x7,2-T7	Spannschraube / Fixing screw / Vis de fixation

ANF-10...R / L

max. Formtiefe: **t = 3.5 mm**
 max. depth of form: **t = 3.5 mm**
 max. profondeur de profil: **t = 3.5 mm**

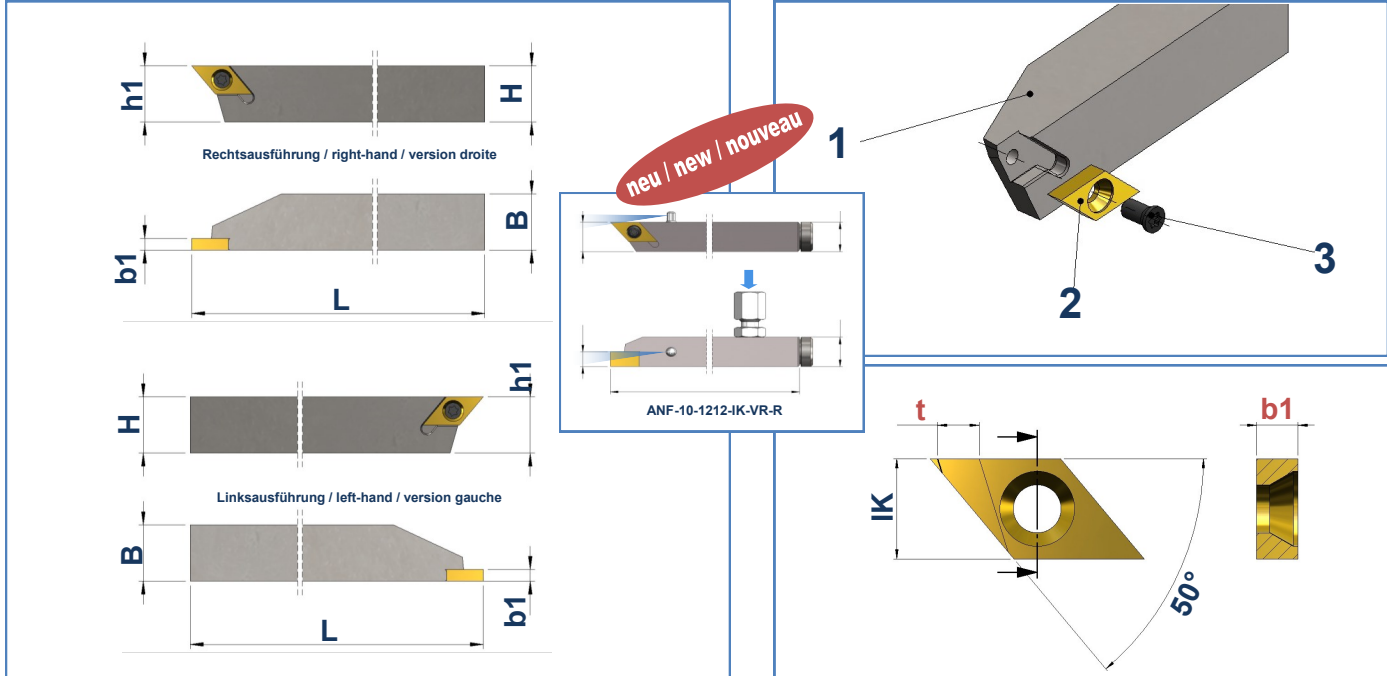

1	Art. Nr. Item no. No. d'art.	Best. Nr. Ref. no. Réf.	Bezeichnung description désignation	B mm	H mm	b1 mm	h1 mm	L mm
	100400	ANF-10-1212-R	Halter / Basic tool holder / Porte-outil de base	12	12	3,5	12	141
100406	ANF-10-1616-R	Halter / Basic tool holder / Porte-outil de base	16	16	3,5	16	126	
100408	ANF-10-2020-R	Halter / Basic tool holder / Porte-outil de base	20	20	3,5	20	126	
107253	ANF-10-2525-R	Halter / Basic tool holder / Porte-outil de base	25	25	3,5	25	126	
100399	ANF-10-1212-L	Halter / Basic tool holder / Porte-outil de base	12	12	3,5	12	141	
100405	ANF-10-1616-L	Halter / Basic tool holder / Porte-outil de base	16	16	3,5	12	126	
100407	ANF-10-2020-L	Halter / Basic tool holder / Porte-outil de base	20	20	3,5	16	126	
135919	ANF-10-1212-IK-VR-R	Halter / Basic tool holder / Porte-outil de base	12	12	3,5	12	130	

2	Art. Nr. Item no. No. d'art.	Best. Nr. Ref. no. Réf.	Bezeichnung description désignation	b1 mm	IK mm	HM-Sorte Carbide grade Nuance de carbure
	100987	FS-10-350-UG-N-G1A-FK	HM-Wendeplatten / Carbide inserts / Plaquettes réversibles	3,5	8,0	FK
100988	FS-10-350-UG-N-G1A-K10	HM-Wendeplatten / Carbide inserts / Plaquettes réversibles	3,5	8,0	K10	
100996	FS-10-400-UG-N-G1A-FK	HM-Wendeplatten / Carbide inserts / Plaquettes réversibles	4,0	8,0	FK	
100997	FS-10-400-UG-N-G1A-K10	HM-Wendeplatten / Carbide inserts / Plaquettes réversibles	4,0	8,0	K10	

3	Art. Nr. Item no. No. d'art.	Best. Nr. Ref. no. Réf.	Bezeichnung description désignation
	107349	Torx M3x8-T10	Spannschraube / Fixing screw / Vis de fixation

ANF-10-6...R / L

max. Formtiefe: **t = 3.5 mm**
 max. depth of form: **t = 3.5 mm**
 max. profondeur de profil: **t = 3.5 mm**

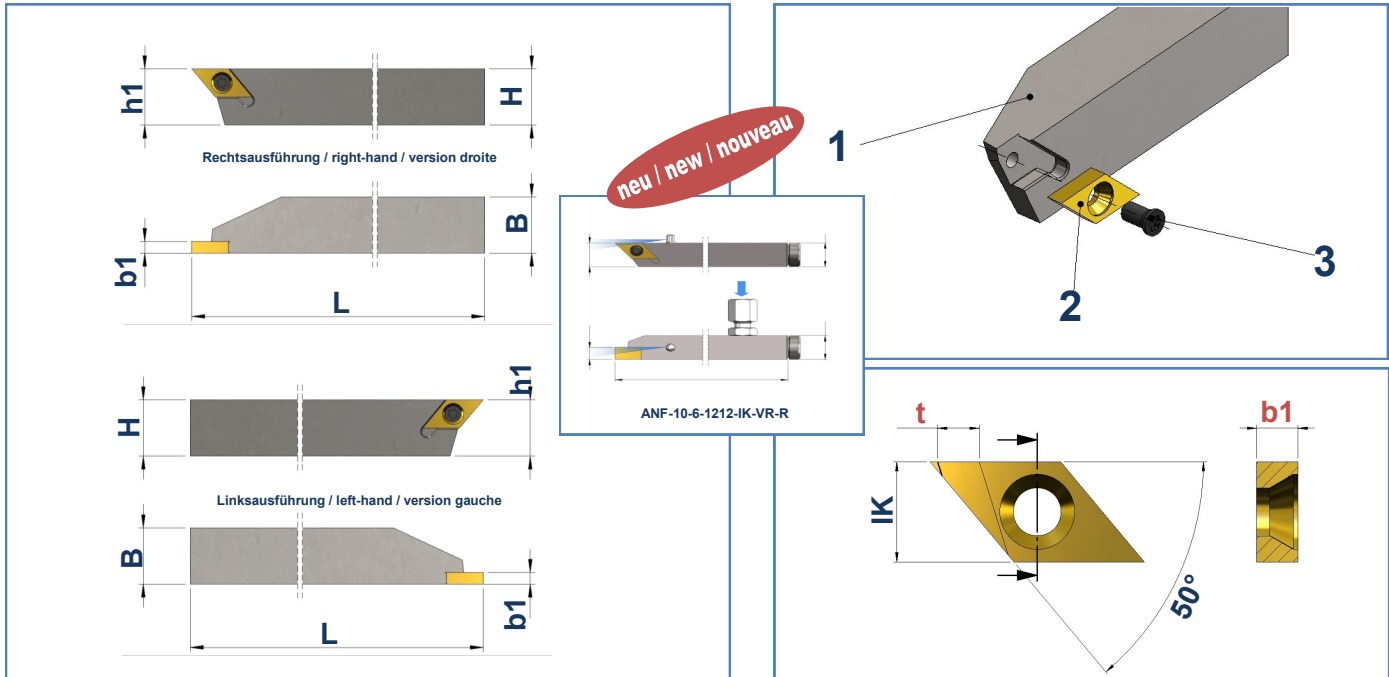

Art. Nr. Item no. No. d'art.	Best. Nr. Ref. no. Réf.	Bezeichnung description désignation	B mm	H mm	b1 mm	h1 mm	L mm	
1	100410	ANF-10-6-1212-R	Halter / Basic tool holder / Porte-outil de base	12	12	6,0	12	141
	100414	ANF-10-6-1616-R	Halter / Basic tool holder / Porte-outil de base	16	16	6,0	16	126
	100416	ANF-10-6-2020-R	Halter / Basic tool holder / Porte-outil de base	20	20	6,0	20	126
	165015	ANF-10-6-2525-R	Halter / Basic tool holder / Porte-outil de base	25	25	6,0	25	126
	100409	ANF-10-6-1212-L	Halter / Basic tool holder / Porte-outil de base	12	12	6,0	12	141
	100413	ANF-10-6-1616-L	Halter / Basic tool holder / Porte-outil de base	16	16	6,0	12	126
	100415	ANF-10-6-2020-L	Halter / Basic tool holder / Porte-outil de base	20	20	6,0	16	126
	165016	ANF-10-6-2525-L	Halter / Basic tool holder / Porte-outil de base	25	25	6,0	25	126
	136745	ANF-10-6-1212-IK-VR-R	Halter / Basic tool holder / Porte-outil de base	12	12	6,0	12	130

Art. Nr. Item no. No. d'art.	Best. Nr. Ref. no. Réf.	Bezeichnung description désignation	b1 mm	IK mm	HM-Sorte Carbide grade Nuance de carbure	
2	101006	FS-10-600-UG-N-G1A-K10	HM-Wendeplatten / Carbide inserts / Plaquettes réversibles	6,0	8,0	K10

Art. Nr. Item no. No. d'art.	Best. Nr. Ref. no. Réf.	Bezeichnung description désignation
3	115980	Torx M3x10-T10
		Spannschraube / Fixing screw / Vis de fixation

ANF-10-8...R / L

max. Formtiefe: **t = 3.5 mm**
 max. depth of form: **t = 3.5 mm**
 max. profondeur de profil: **t = 3.5 mm**

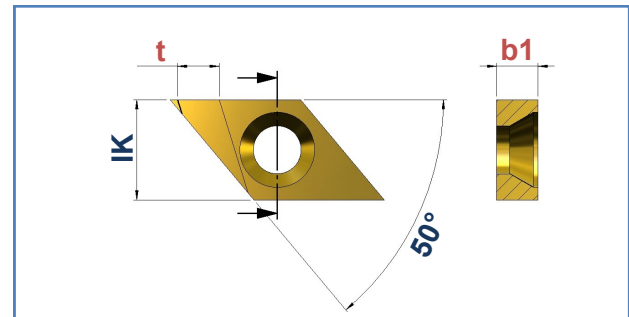
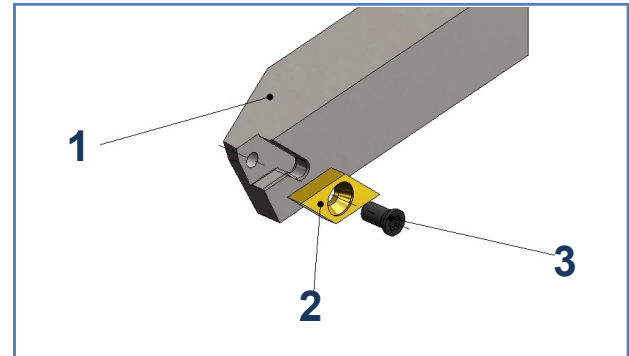
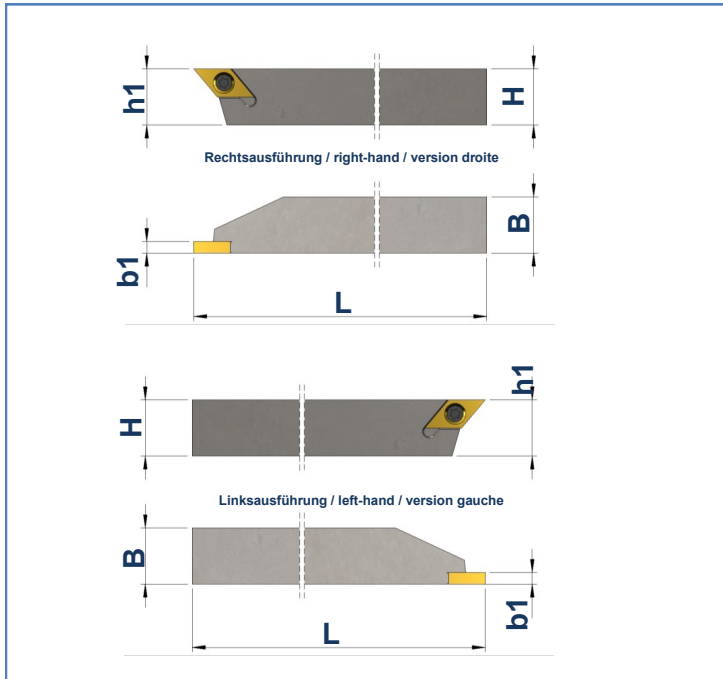

1	Art. Nr. Item no. No. d'art.	Best. Nr. Ref. no. Réf.	Bezeichnung description désignation	B mm	H mm	b1 mm	h1 mm	L mm
	100418	ANF-10-8-1212-R	Halter / Basic tool holder / Porte-outil de base	12	12	8,0	12	141
100422	ANF-10-8-1616-R	Halter / Basic tool holder / Porte-outil de base	16	16	8,0	16	126	
100424	ANF-10-8-2020-R	Halter / Basic tool holder / Porte-outil de base	20	20	8,0	20	126	
165017	ANF-10-8-2525-R	Halter / Basic tool holder / Porte-outil de base	25	25	8,0	25	126	
100417	ANF-10-8-1212-L	Halter / Basic tool holder / Porte-outil de base	12	12	8,0	12	141	
100421	ANF-10-8-1616-L	Halter / Basic tool holder / Porte-outil de base	16	16	8,0	12	126	
100423	ANF-10-8-2020-L	Halter / Basic tool holder / Porte-outil de base	20	20	8,0	16	126	
165018	ANF-10-8-2525-L	Halter / Basic tool holder / Porte-outil de base	25	25	8,0	25	126	

2	Art. Nr. Item no. No. d'art.	Best. Nr. Ref. no. Réf.	Bezeichnung description désignation	b1 mm	IK mm	HM-Sorte Carbide grade Nuance de carbure
	101012	FS-10-800-UG-N-G1A-K10	HM-Wendeplatten / Carbide inserts / Plaquettes réversibles	8,0	8,0	K10

3	Art. Nr. Item no. No. d'art.	Best. Nr. Ref. no. Réf.	Bezeichnung description désignation
	102613	Torx S-309950-T8	Spannschraube / Fixing screw / Vis de fixation

ANF-10-8-...V-R

Verstärkter Plattensitz
 Reinforced insert seat /
 Siège de la plaquette renforcée

neu / new / nouveau

max. Formtiefe: **t = 3.5 mm**
 max. depth of form: **t = 3.5 mm**
 max. profondeur de profil: **t = 3.5 mm**

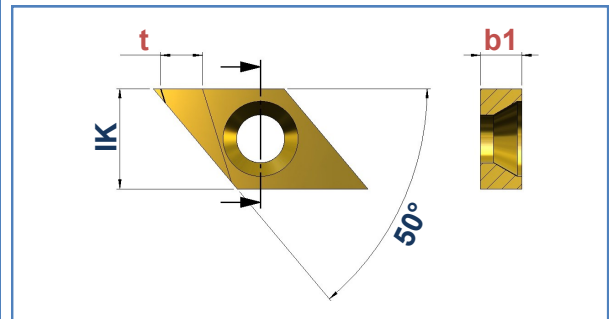
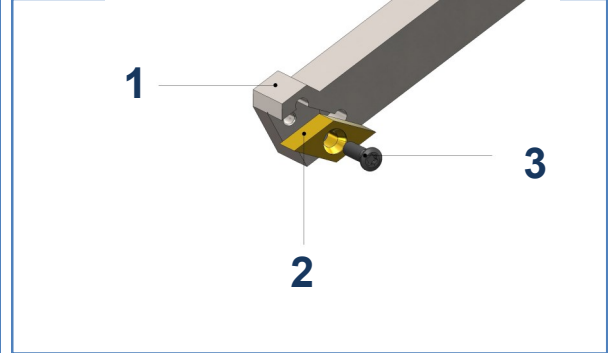
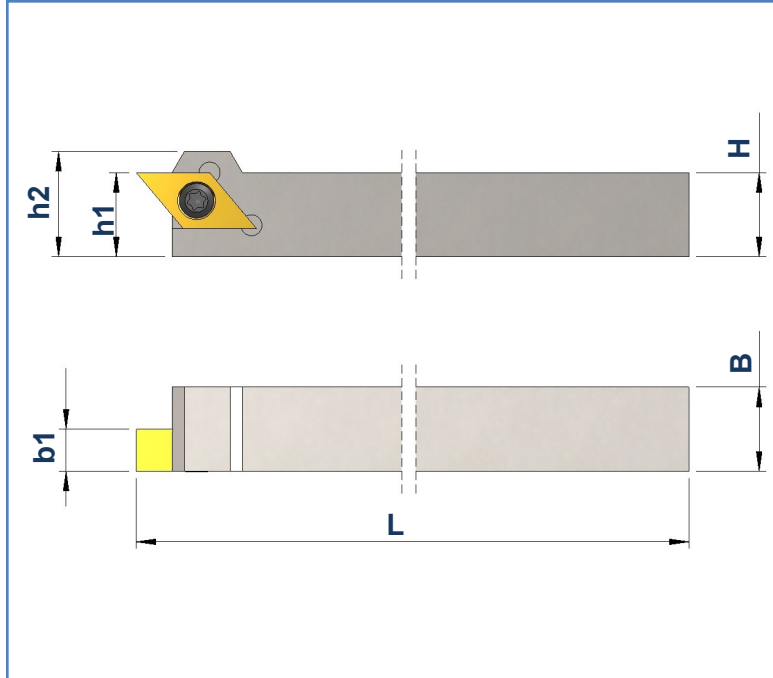

1	Art. Nr. Item no. No. d'art.	Best. Nr. Ref. no. Réf.	Bezeichnung description désignation	B mm	H mm	h2 mm	b1 mm	h1 mm	L mm
		127666	ANF-10-8-1212-V-R	Halter / Basic tool holder / Porte-outil de base	12	12	15	8,0	12
	133557	ANF-10-8-1616-V-R	Halter / Basic tool holder / Porte-outil de base	16	16	19	8,0	16	131

2	Art. Nr. Item no. No. d'art.	Best. Nr. Ref. no. Réf.	Bezeichnung description désignation	b1 mm	IK mm	HM-Sorte Carbide grade Nuance de carbure
		101012	FS-10-800-UG-N-G1A-K10	HM-Wendepplatten / Carbide inserts / Plaquettes réversibles	8,0	8,0

3	Art. Nr. Item no. No. d'art.	Best. Nr. Ref. no. Réf.	Bezeichnung description désignation
		102613	Torx S-309950-T8

ANF-12-6...R / L

max. Formtiefe: **t = 5.5 mm**
 max. depth of form: **t = 5.5 mm**
 max. profondeur de profil: **t = 5.5 mm**

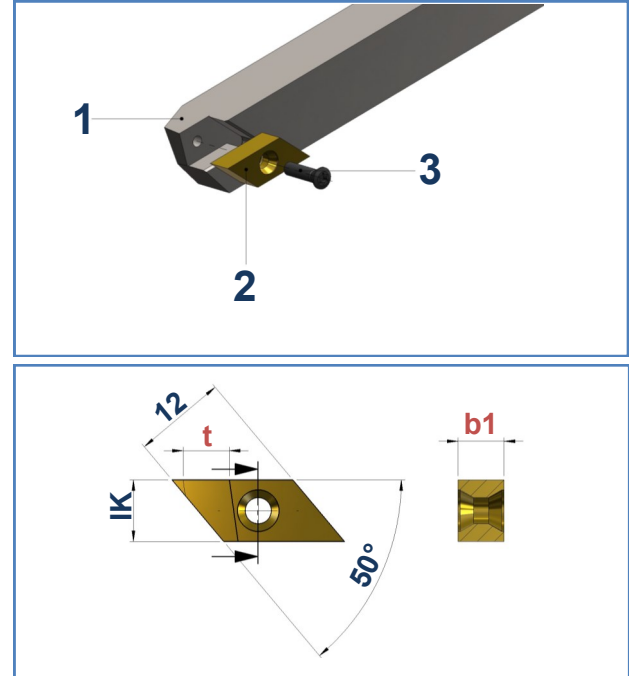
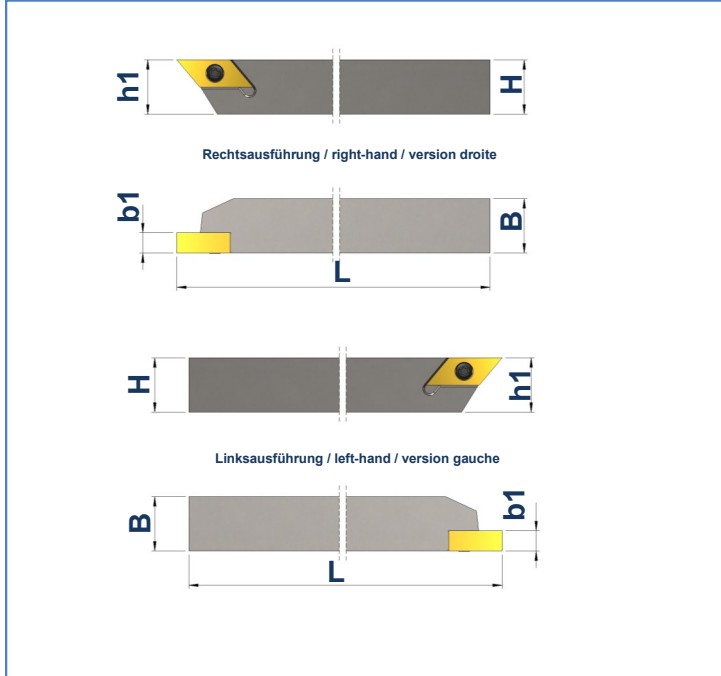

1	Art. Nr. Item no. No. d'art.	Best. Nr. Ref. no. Réf.	Bezeichnung description désignation	B mm	H mm	b1 mm	h1 mm	L mm
	100426	ANF-12-6-1212-R	Halter / Basic tool holder / Porte-outil de base	12	12	6,0	12	141
100430	ANF-12-6-1616-R	Halter / Basic tool holder / Porte-outil de base	16	16	6,0	16	126	
100432	ANF-12-6-2020-R	Halter / Basic tool holder / Porte-outil de base	20	20	6,0	20	126	
136354	ANF-12-6-2525-R	Halter / Basic tool holder / Porte-outil de base	25	25	6,0	25	126	
100425	ANF-12-6-1212-L	Halter / Basic tool holder / Porte-outil de base	12	12	6,0	12	141	
100429	ANF-12-6-1616-L	Halter / Basic tool holder / Porte-outil de base	16	16	6,0	16	126	
100431	ANF-12-6-2020-L	Halter / Basic tool holder / Porte-outil de base	20	20	6,0	20	126	
139507	ANF-12-6-2525-L	Halter / Basic tool holder / Porte-outil de base	25	25	6,0	25	126	

2	Art. Nr. Item no. No. d'art.	Best. Nr. Ref. no. Réf.	Bezeichnung description désignation	b1 mm	IK mm	HM-Sorte Carbide grade Nuance de carbure
	101018	FS-12-600-UG-N-G1A-K10	HM-Wendepplatten / Carbide inserts / Plaquettes réversibles	6,0	8,0	K10

3	Art. Nr. Item no. No. d'art.	Best. Nr. Ref. no. Réf.	Bezeichnung description désignation
	115980	Torx M3x10-T10	Spannschraube / Fixing screw / Vis de fixation

ANF-12-8...R / L

max. Formtiefe: **t = 5.5 mm**
 max. depth of form: **t = 5.5 mm**
 max. profondeur de profil: **t = 5.5 mm**

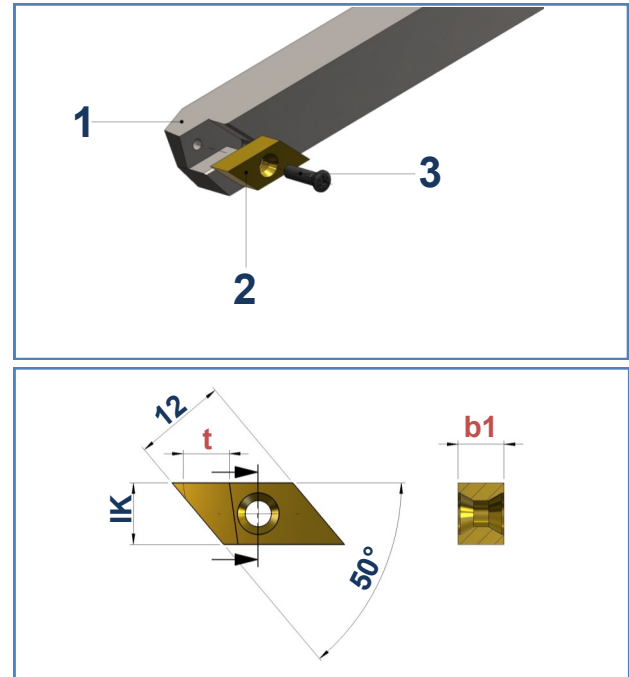
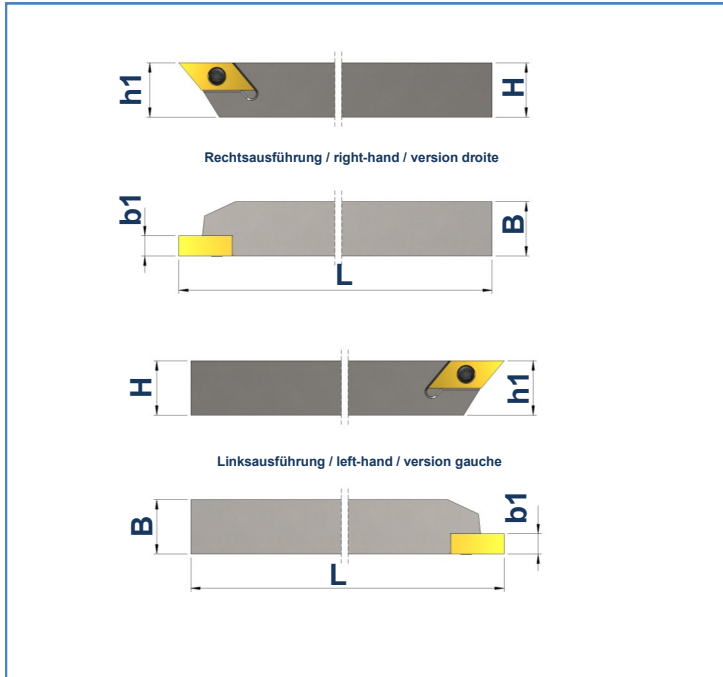

1	Art. Nr. Item no. No. d'art.	Best. Nr. Ref. no. Réf.	Bezeichnung description désignation	B mm	H mm	b1 mm	h1 mm	L mm
	100434	ANF-12-8-1212-R	Halter / Basic tool holder / Porte-outil de base	12	12	8,0	12	141
100438	ANF-12-8-1616-R	Halter / Basic tool holder / Porte-outil de base	16	16	8,0	16	126	
100440	ANF-12-8-2020-R	Halter / Basic tool holder / Porte-outil de base	20	20	8,0	20	126	
165013	ANF-12-8-2525-R	Halter / Basic tool holder / Porte-outil de base	25	25	8,0	25	126	
100433	ANF-12-8-1212-L	Halter / Basic tool holder / Porte-outil de base	12	12	8,0	12	141	
100437	ANF-12-8-1616-L	Halter / Basic tool holder / Porte-outil de base	16	16	8,0	16	126	
100439	ANF-12-8-2020-L	Halter / Basic tool holder / Porte-outil de base	20	20	8,0	20	126	
165014	ANF-12-8-2525-L	Halter / Basic tool holder / Porte-outil de base	25	25	8,0	25	126	

2	Art. Nr. Item no. No. d'art.	Best. Nr. Ref. no. Réf.	Bezeichnung description désignation	b1 mm	IK mm	HM-Sorte Carbide grade Nuance de carbure
	101024	FS-12-800-UG-N-G1A-K10	HM-Wendepplatten / Carbide inserts / Plaquettes réversibles	8,0	8,0	K10

3	Art. Nr. Item no. No. d'art.	Best. Nr. Ref. no. Réf.	Bezeichnung description désignation
	102613	Torx S-309950-T8	Spannschraube / Fixing screw / Vis de fixation

TA-4-85-...-R / L

max. Formtiefe: **t = 3,6 mm**
 max. depth of form: **t = 3,6 mm**
 max. profondeur de profil: **t = 3,6 mm**

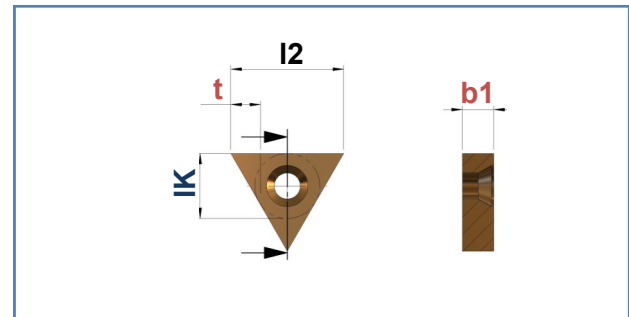
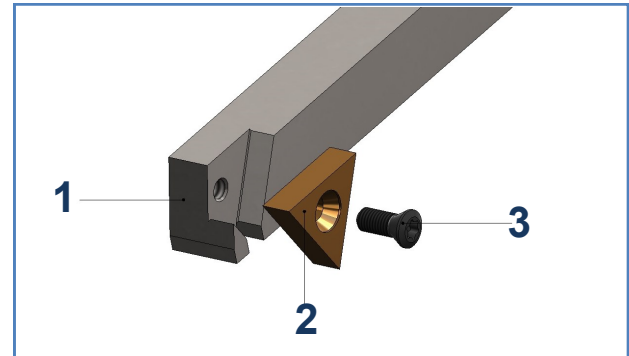
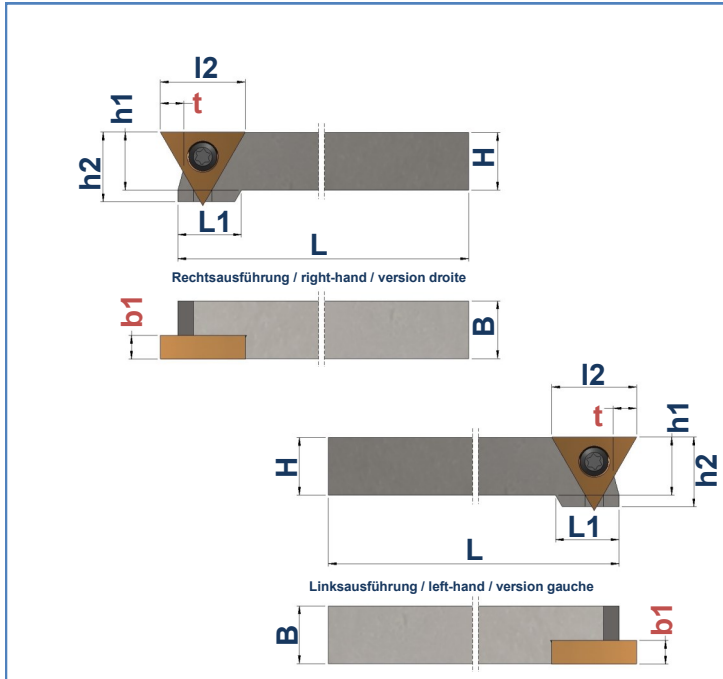

1	Art. Nr. Item no. No. d'art.	Best. Nr. Ref. no. Réf.	Bezeichnung description désignation	B mm	H mm	b1 mm	h1 mm	h2 mm	L mm	L1 mm
	116770	TA-4-85-1010-R	Halter / Basic tool holder / Porte-outil de base	10	10	4,1	10	12	130	11
116771	TA-4-85-1212-R	Halter / Basic tool holder / Porte-outil de base	12	12	4,1	12	-	130	-	
116772	TA-4-85-1616-R	Halter / Basic tool holder / Porte-outil de base	16	16	4,1	16	-	130	-	
116773	TA-4-85-2020-R	Halter / Basic tool holder / Porte-outil de base	20	20	4,1	20	-	130	-	
116774	TA-4-85-1010-L	Halter / Basic tool holder / Porte-outil de base	10	10	4,1	10	12	130	11	
116775	TA-4-85-1212-L	Halter / Basic tool holder / Porte-outil de base	12	12	4,1	12	-	130	-	
116776	TA-4-85-1616-L	Halter / Basic tool holder / Porte-outil de base	16	16	4,1	16	-	130	-	
116777	TA-4-85-2020-L	Halter / Basic tool holder / Porte-outil de base	20	20	4,1	20	-	130	-	

2	Art. Nr. Item no. No. d'art.	Best. Nr. Ref. no. Réf.	Bezeichnung description désignation	b1 mm	IK mm	l2 mm	HM-Sorte Carbide grade Nuance de carbure
	118193	TA-85-4-N-UFK2	HM-Wendeplatten / Carbide inserts / Plaquettes réversibles	4,1	8,5	14,7	UFK-2

3	Art. Nr. Item no. No. d'art.	Best. Nr. Ref. no. Réf.	Bezeichnung description désignation
	107349	Torx M3X8-T10	Spannschraube / Fixing screw / Vis de fixation

TA-4-85-1212-IK-VR-R

neu / new / nouveau

max. Formtiefe: $t = 3,6$ mm
 max. depth of form: $t = 3,6$ mm
 max. profondeur de profil: $t = 3,6$ mm

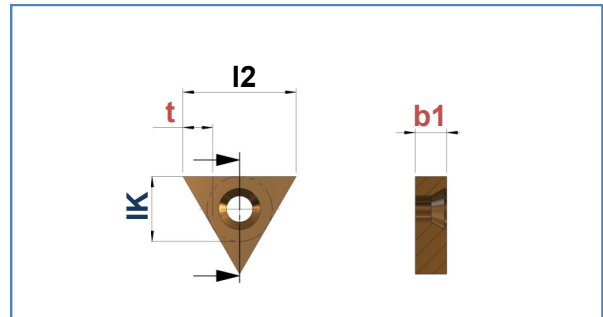
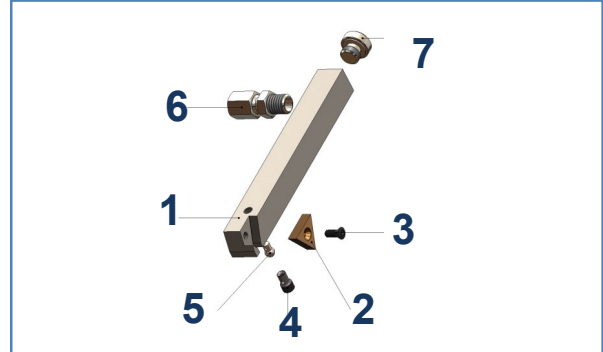
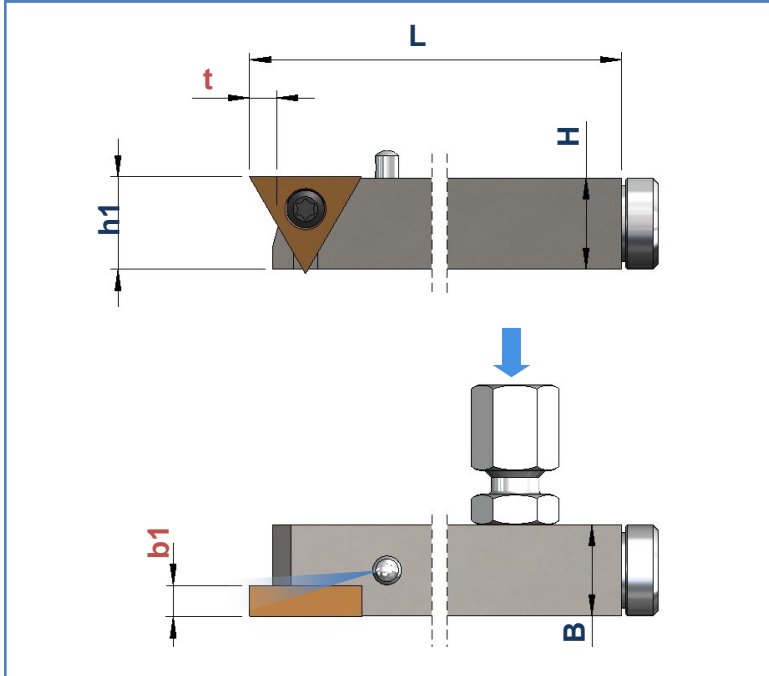

1	Art. Nr. Item no. No. d'art.	Best. Nr. Ref. no. Réf.	Bezeichnung description désignation	B mm	H mm	b1 mm	h1 mm	L mm
	147299	TA-4-85-1212-IK-VR-R	Halter / Basic tool holder / Porte-outil de base	12	12	4,1	12	103

2	Art. Nr. Item no. No. d'art.	Best. Nr. Ref. no. Réf.	Bezeichnung description désignation	b1 mm	IK mm	I2 mm	HM-Sorte Carbide grade Nuance de carbure
	118193	TA-85-4-N-UFK2	HM-Wendeplatten / Carbide inserts / Plaquettes réversibles	4,1	8,5	14,7	UFK-2

	Art. Nr. Item no. No. d'art.	Best. Nr. Ref. no. Réf.	Bezeichnung description désignation
3	107349	Torx M3X8-T10	Spannschraube / Fixing screw / Vis de fixation
4	125414	KS-12	Klemmschraube / Fixing screw / Vis de fixation
5	126018	KD-42-U	Kühlmitteldüse / coolant nozzle / buse d'arrosage
6	125581	GE-04-LLM-CF-M8x1	Gerade Einschraubverschraubung / straight screw-in connection / raccord droit
7	125586	VSTI-M08x1-ED-CF	Verschluss-Stopfen / plug / bouchon

Mit Innenkühlung / With internal coolant supply / Avec arrosage central

TA-10-95-...-R / L

neu / new / nouveau

max. Formtiefe: $t = 3,6$ mm
 max. depth of form: $t = 3,6$ mm
 max. profondeur de profil: $t = 3,6$ mm

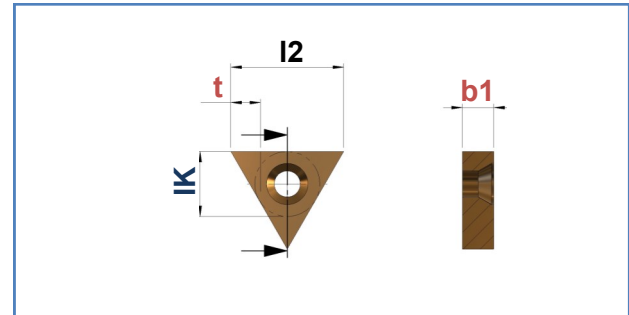
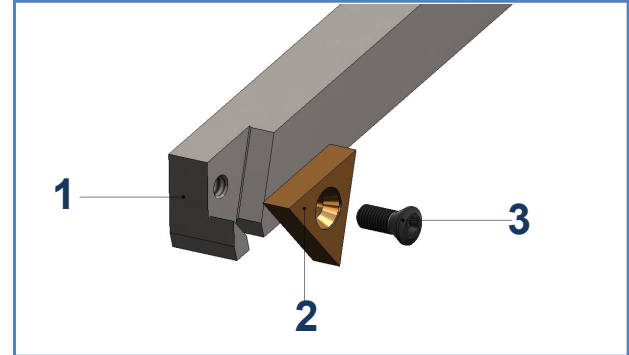
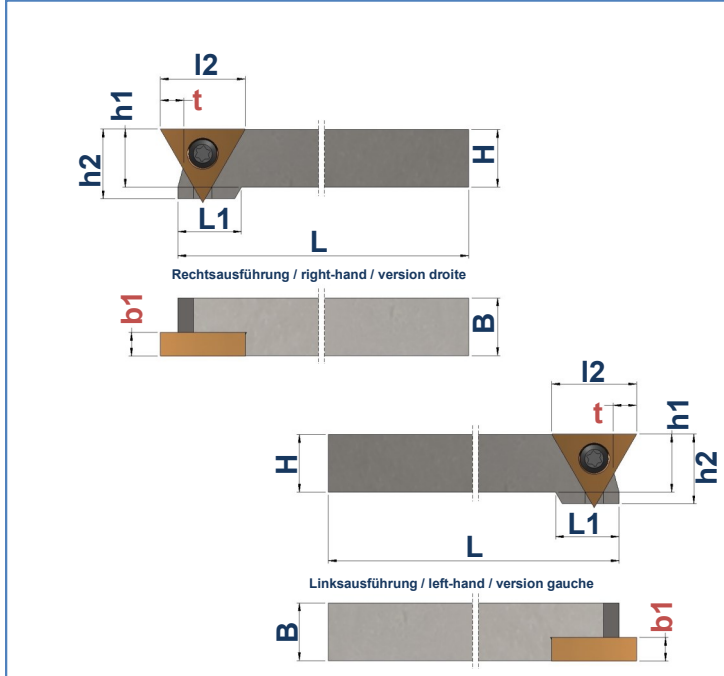

1	Art. Nr. Item no. No. d'art.	Best. Nr. Ref. no. Réf.	Bezeichnung description désignation	B mm	H mm	b1 mm	h1 mm	h2 mm	L mm	L1 mm
	165094	TA-10-95-1616-R	Halter / Basic tool holder / Porte-outil de base	16	16	10	16	-	100	-
165096	TA-10-95-2020-R	Halter / Basic tool holder / Porte-outil de base	20	20	10	20	-	100	-	
165093	TA-10-95-1616-L	Halter / Basic tool holder / Porte-outil de base	16	16	10	16	-	100	-	
165095	TA-10-95-2020-L	Halter / Basic tool holder / Porte-outil de base	20	20	10	20	-	100	-	

2	Art. Nr. Item no. No. d'art.	Best. Nr. Ref. no. Réf.	Bezeichnung description désignation	b1 mm	IK mm	l2 mm	HM-Sorte Carbide grade Nuance de carbure
	141291	TNEX-161000-K20M	HM-Wendeplatten / Carbide inserts / Plaquettes réversibles	10	9,5	16,5	K20

3	Art. Nr. Item no. No. d'art.	Best. Nr. Ref. no. Réf.	Bezeichnung description désignation
	141881	Torx M3,5X13-T15	Spannschraube / Fixing screw / Vis de fixation

TA-7-112-...-R / L

max. Formtiefe: **t = 5 mm**
 max. depth of form: **t = 5 mm**
 max. profondeur de profil: **t = 5 mm**

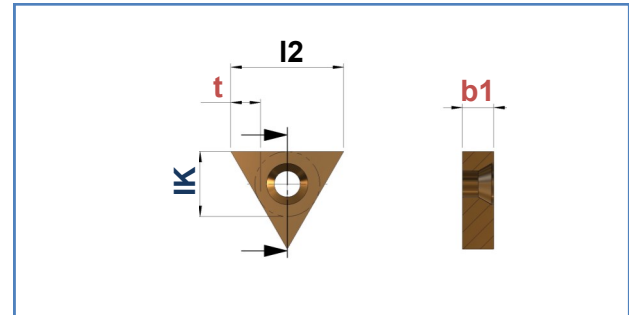
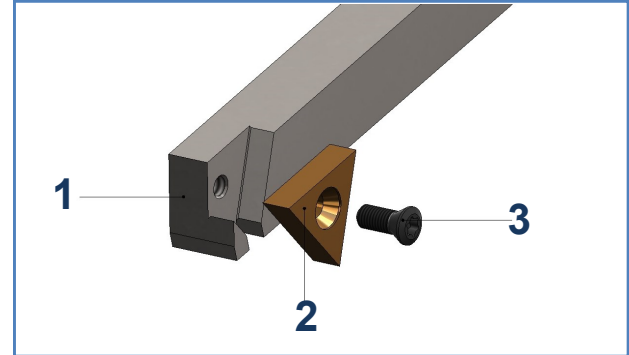
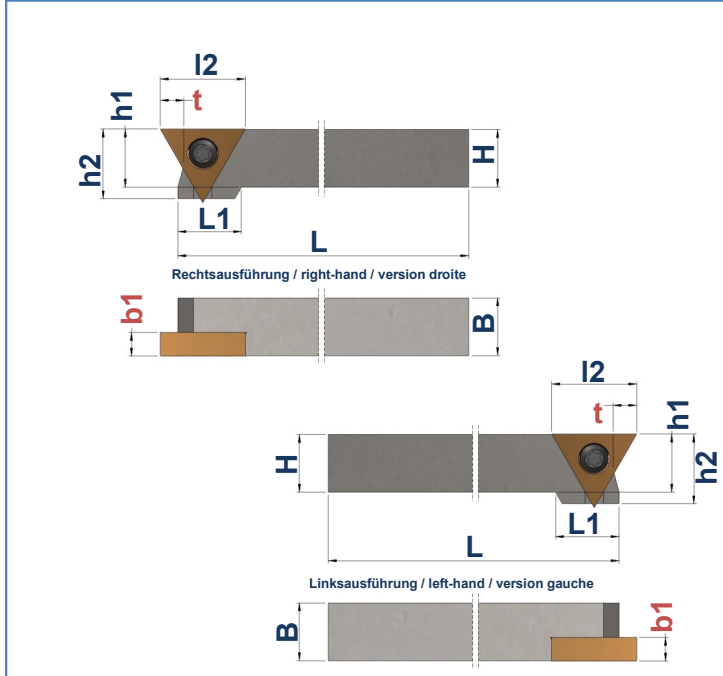

1	Art. Nr. Item no. No. d'art.	Best. Nr. Ref. no. Réf.	Bezeichnung description désignation	B mm	H mm	b1 mm	h1 mm	h2 mm	L mm	L1 mm
	116779	TA-7-112-1212-R	Halter / Basic tool holder / Porte-outil de base	12	12	7,1	12	16	130	15
116780	TA-7-112-1616-R	Halter / Basic tool holder / Porte-outil de base	16	16	7,1	16	-	130	-	
116781	TA-7-112-2020-R	Halter / Basic tool holder / Porte-outil de base	20	20	7,1	20	-	130	-	
116782	TA-7-112-2525-R	Halter / Basic tool holder / Porte-outil de base	25	25	7,1	25	-	130	-	
116783	TA-7-112-1212-L	Halter / Basic tool holder / Porte-outil de base	12	12	7,1	12	16	130	15	
116784	TA-7-112-1616-L	Halter / Basic tool holder / Porte-outil de base	16	16	7,1	16	-	130	-	
116785	TA-7-112-2020-L	Halter / Basic tool holder / Porte-outil de base	20	20	7,1	20	-	130	-	
116786	TA-7-112-2525-L	Halter / Basic tool holder / Porte-outil de base	25	25	7,1	25	-	130	-	

2	Art. Nr. Item no. No. d'art.	Best. Nr. Ref. no. Réf.	Bezeichnung description désignation	b1 mm	IK mm	l2 mm	HM-Sorte Carbide grade Nuance de
	117580	TA-112-7-N-UFK2	HM-Wendepplatten / Carbide inserts / Plaquettes réversibles	7,1	11,2	19,4	UFK-2

3	Art. Nr. Item no. No. d'art.	Best. Nr. Ref. no. Réf.	Bezeichnung description désignation
	102218	Torx M4X11,5-T15	Spannschraube / Fixing screw / Vis de fixation

TA-8-138-...-R / L

max. Formtiefe: **t = 6,2 mm**
 max. depth of form: **t = 6,2 mm**
 max. profondeur de profil: **t = 6,2 mm**

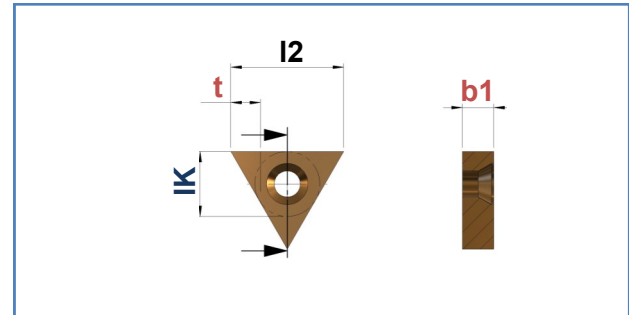
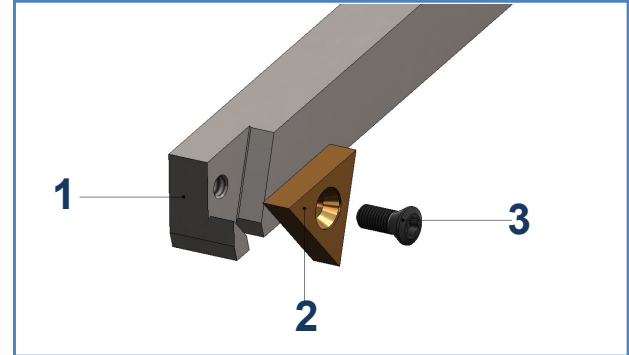
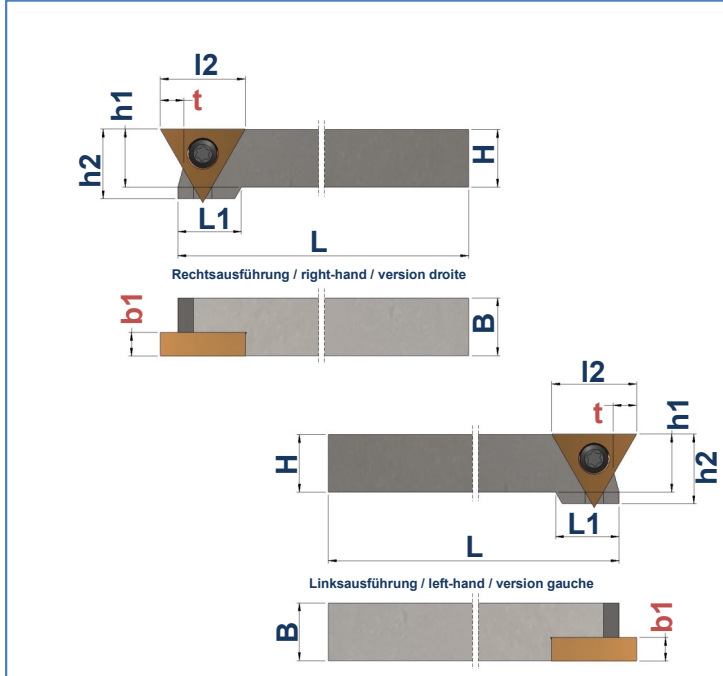

1	Art. Nr. Item no. No. d'art.	Best. Nr. Ref. no. Réf.	Bezeichnung description désignation	B mm	H mm	b1 mm	h1 mm	h2 mm	L mm	L1 mm
	116787	TA-8-138-1214-R	Halter / Basic tool holder / Porte-outil de base	14	12	8,1	14	20	130	18
116788	TA-8-138-1616-R	Halter / Basic tool holder / Porte-outil de base	16	16	8,1	16	20	130	16	
116789	TA-8-138-2020-R	Halter / Basic tool holder / Porte-outil de base	20	20	8,1	20	-	130	-	
116790	TA-8-138-2525-R	Halter / Basic tool holder / Porte-outil de base	25	25	8,1	25	-	130	-	
116791	TA-8-138-1214-L	Halter / Basic tool holder / Porte-outil de base	14	12	8,1	14	20	130	18	
116792	TA-8-138-1616-L	Halter / Basic tool holder / Porte-outil de base	16	16	8,1	16	20	130	16	
116793	TA-8-138-2020-L	Halter / Basic tool holder / Porte-outil de base	20	20	8,1	20	-	130	-	
116794	TA-8-138-2525-L	Halter / Basic tool holder / Porte-outil de base	25	25	8,1	25	-	130	-	

2	Art. Nr. Item no. No. d'art.	Best. Nr. Ref. no. Réf.	Bezeichnung description désignation	b1 mm	IK mm	l2 mm	HM-Sorte Carbide grade Nuance de
	118192	TA-138-8-N-UFK2	HM-Wendepplatten / Carbide inserts / Plaquettes réversibles	8,1	13,8	23,9	UFK-2

3	Art. Nr. Item no. No. d'art.	Best. Nr. Ref. no. Réf.	Bezeichnung description désignation
	102219	Torx M5X13-T25	Spannschraube / Fixing screw / Vis de fixation

FHGU-ES-07-...

neu / new / nouveau

max. Formtiefe: **t = 6 mm**
 max. depth of form: **t = 6 mm**
 max. profondeur de profil: **t = 6 mm**

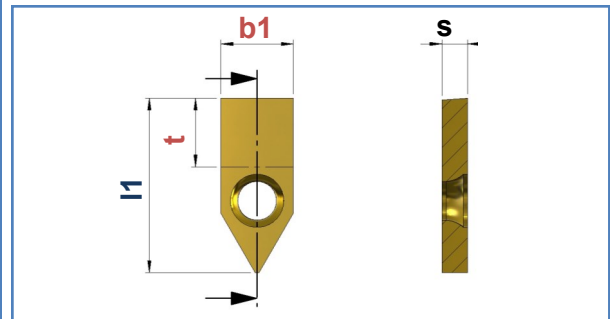
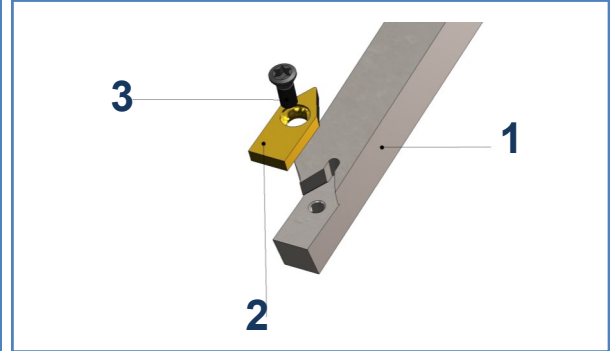
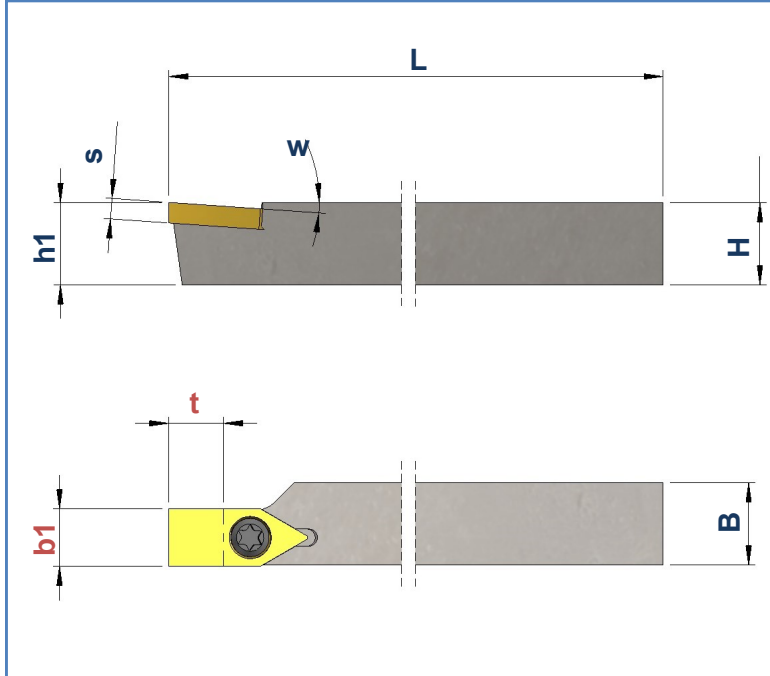

1	Art. Nr. Item no. No. d'art.	Best. Nr. Ref. no. Réf.	Bezeichnung description désignation	B	H	b1	h1	w	L
				mm	mm	mm	mm		mm
	167580	FHGU-ES-07-0808-L	Halter / Basic tool holder / Porte-outil de base	8	8	7,4	8	0°	140
	160579	FHGU-ES-07-0808-R	Halter / Basic tool holder / Porte-outil de base	8	8	7,4	8	0°	140
	160398	FHGU-ES-07-1010-R	Halter / Basic tool holder / Porte-outil de base	10	10	7,4	10	0°	140
	160399	FHGU-ES-07-1212-R	Halter / Basic tool holder / Porte-outil de base	12	12	7,4	12	0°	140
	160403	FHGU-ES-07-1616-R	Halter / Basic tool holder / Porte-outil de base	16	16	7,4	16	0°	125
	160404	FHGU-ES-07-2020-R	Halter / Basic tool holder / Porte-outil de base	20	20	7,4	20	0°	125

2	Art. Nr. Item no. No. d'art.	Best. Nr. Ref. no. Réf.	Bezeichnung description désignation	b1	l1	S	HM-Sorte Carbide grade Nuance de carbure
				mm	mm	mm	
	137767	WP-GU-ES070001N-K10	HM-Wechselplatten/ Carbide inserts / Plaquettes échangeables	7,4	16,1	2,5	K10

3	Art. Nr. Item no. No. d'art.	Best. Nr. Ref. no. Réf.	Bezeichnung description désignation
		102206	M2,5x7,2-T7

FHGU-ES-08-...

neu / new / nouveau

max. Formtiefe: **t = 8 mm**
 max. depth of form: **t = 8 mm**
 max. profondeur de profil: **t = 8 mm**

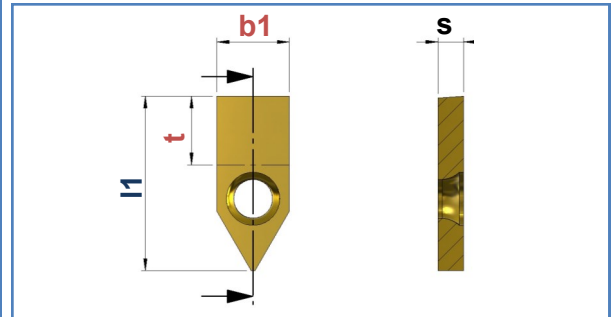
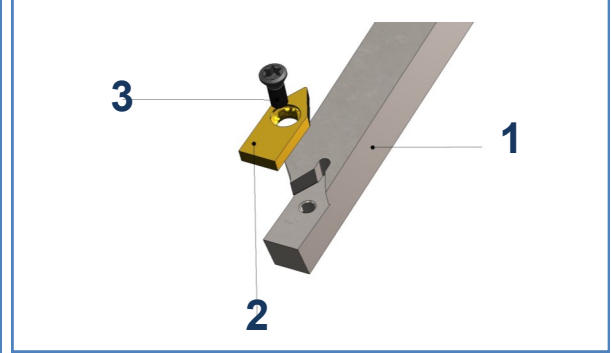
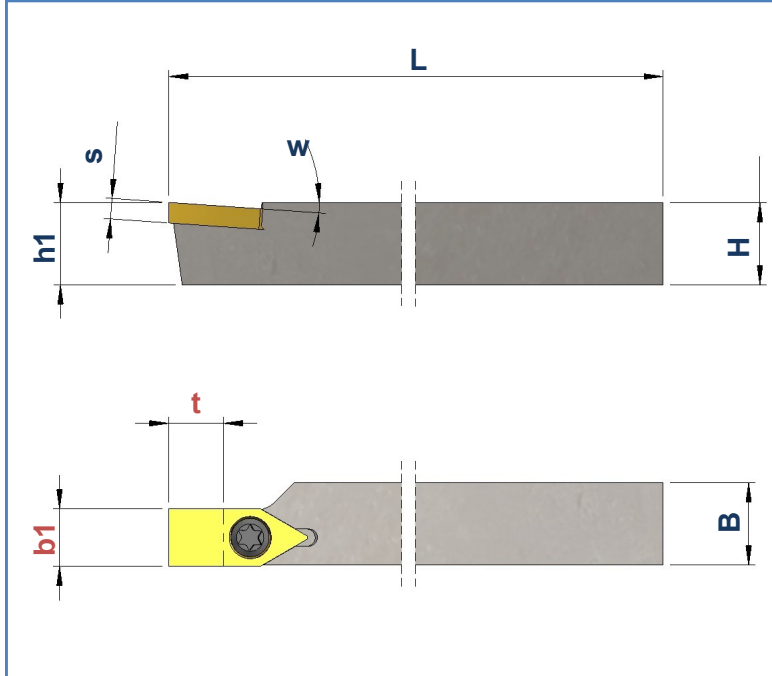

1	Art. Nr. Item no. No. d'art.	Best. Nr. Ref. no. Réf.	Bezeichnung description désignation	B	H	b1	h1	w	L
				mm	mm	mm	mm		mm
	167573	FHGU-ES-08-0808-N	Halter / Basic tool holder / Porte-outil de base	8	8	8,4	8	0°	140
	160364	FHGU-ES-08-1010-R	Halter / Basic tool holder / Porte-outil de base	10	10	8,4	10	0°	140
	160367	FHGU-ES-08-1212-R	Halter / Basic tool holder / Porte-outil de base	12	12	8,4	12	0°	140
	160368	FHGU-ES-08-1616-R	Halter / Basic tool holder / Porte-outil de base	16	16	8,4	16	0°	125
	160369	FHGU-ES-08-2020-R	Halter / Basic tool holder / Porte-outil de base	20	20	8,4	20	0°	125

2	Art. Nr. Item no. No. d'art.	Best. Nr. Ref. no. Réf.	Bezeichnung description désignation	b1	l1	S	HM-Sorte Carbide grade Nuance de carbure
				mm	mm	mm	
	137766	WP-GU-ES080001N-K10	HM-Wechselplatten / Carbide inserts / Plaquettes échangeables	8,4	20,3	3	K10

3	Art. Nr. Item no. No. d'art.	Best. Nr. Ref. no. Réf.	Bezeichnung description désignation
		118297	M3,5x9-T15

H-TFP-...

Eine Platte für große Stechtiefen
 An insert for large penetration depth
 Une plaquette pour la grande profondeur d'usinage

neu / new / nouveau

max. Formtiefe: **t = 15 mm**
 max. depth of form: **t = 15 mm**
 max. profondeur de profil: **t = 15 mm**

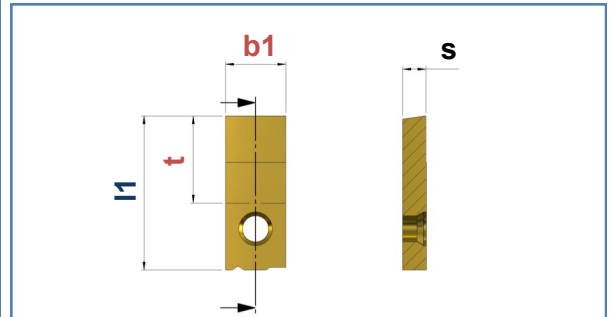
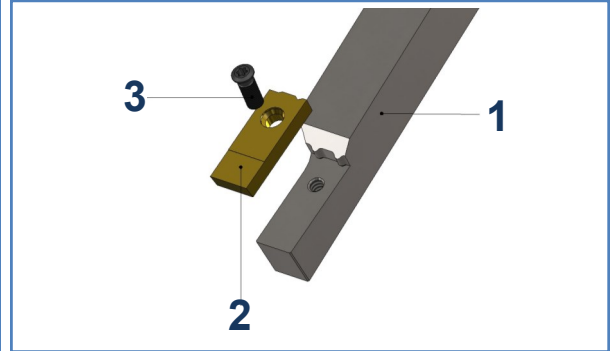
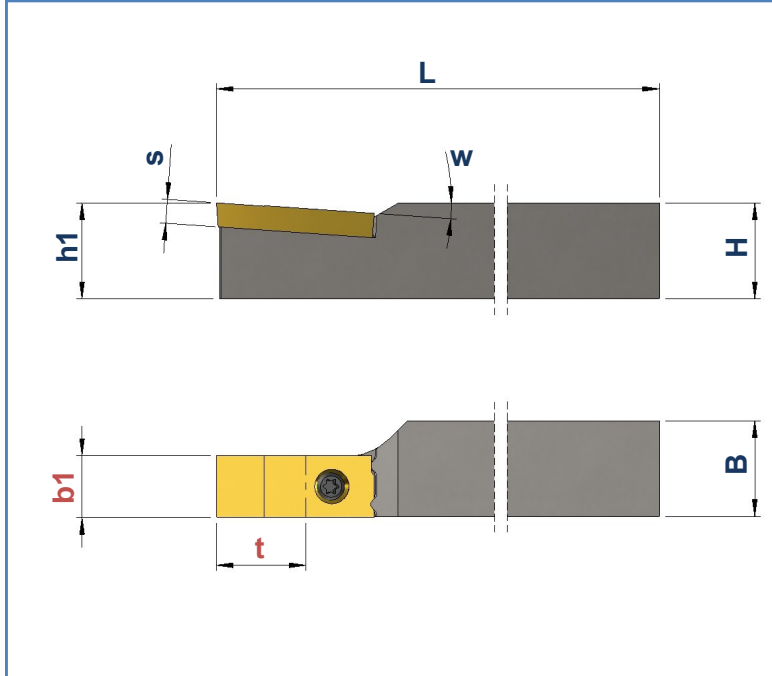

1	Art. Nr. Item no. No. d'art.	Best. Nr. Ref. no. Réf.	Bezeichnung description désignation	B	H	b1	h1	w	L
				mm	mm	mm	mm		mm
	145420	H-TFP-1212-R	Halter / Basic tool holder / Porte-outil de base	12	12	10	12	0°	140
	145421	H-TFP-1616-R	Halter / Basic tool holder / Porte-outil de base	16	16	10	16	0°	125
	145422	H-TFP-2020-R	Halter / Basic tool holder / Porte-outil de base	20	20	10	20	0°	125

2	Art. Nr. Item no. No. d'art.	Best. Nr. Ref. no. Réf.	Bezeichnung description désignation	b1	l1	S	HM-Sorte Carbide grade Nuance de carbure
				mm	mm	mm	
	145831	TFP-10-26-4-FK30	HM-Wechselplatten / Carbide inserts / Plaquettes échangeables	10	26,5	4	FK

3	Art. Nr. Item no. No. d'art.	Best. Nr. Ref. no. Réf.	Bezeichnung description désignation
		102218	M4X11,5-T15

FHFPN-12-...-0-NF

max. Formtiefe: $t = 6,5$ mm
 max. depth of form: $t = 6,5$ mm
 max. profondeur de profil: $t = 6,5$ mm

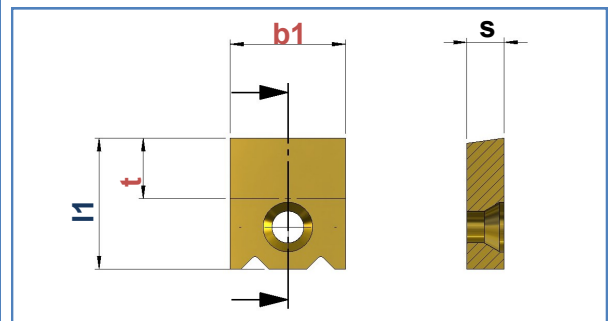
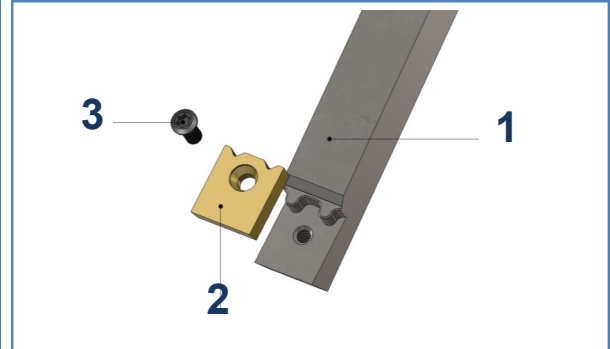
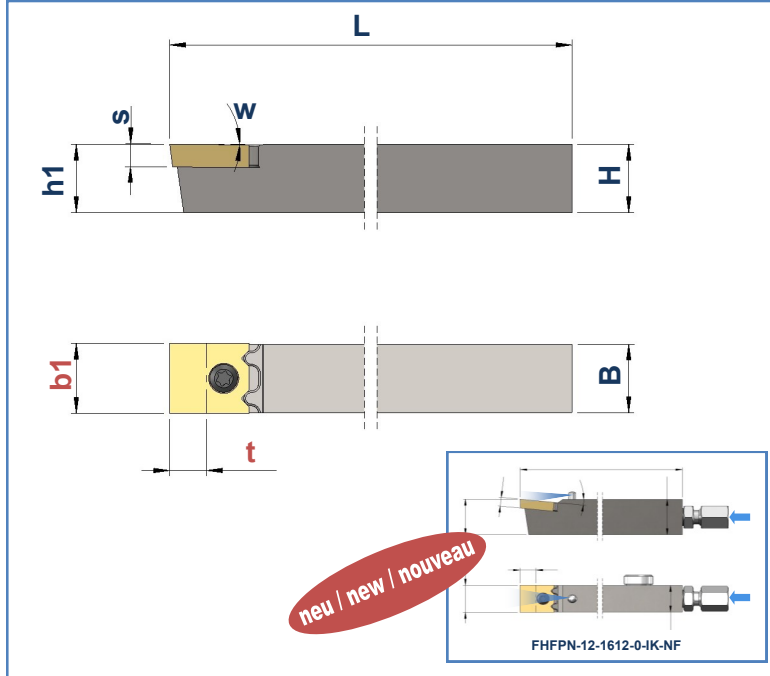

1	Art. Nr. Item no. No. d'art.	Best. Nr. Ref. no. Réf.	Bezeichnung description désignation	B	H	b1	h1	w	L
				mm	mm	mm	mm		mm
	107285	FHFPN-12-1010-0-NF	Halter / Basic tool holder / Porte-outil de base	10	10	12	10	0°	140
	118173	FHFPN-12-1210-0-NF	Halter / Basic tool holder / Porte-outil de base	10	12	12	12	0°	140
	108697	FHFPN-12-1610-0-NF	Halter / Basic tool holder / Porte-outil de base	10	16	12	16	0°	125
	108698	FHFPN-12-2010-0-NF	Halter / Basic tool holder / Porte-outil de base	10	20	12	20	0°	125
	107288	FHFPN-12-1212-0-NF	Halter / Basic tool holder / Porte-outil de base	12	12	12	12	0°	140
	107599	FHFPN-12-1612-0-NF	Halter / Basic tool holder / Porte-outil de base	12	16	12	16	0°	125
	108663	FHFPN-12-2012-0-NF	Halter / Basic tool holder / Porte-outil de base	12	20	12	20	0°	125
	131034	FHFPN-12-2525-0-R	Halter / Basic tool holder / Porte-outil de base	25	25	12	25	0°	125
	125519	FHFPN-12-1612-0-IK-NF	Halter / Basic tool holder / Porte-outil de base	12	16	12	16	0°	140

2	Art. Nr. Item no. No. d'art.	Best. Nr. Ref. no. Réf.	Bezeichnung description désignation	b1	l1	S	HM-Sorte Carbide grade Nuance de carbure
				mm	mm	mm	
	107279	FPN-12-4-N-UFK-2	HM-Wechselplatten / Carbide inserts / Plaquettes échangeables	12	14,5	4	UFK-2
	107280	FPN-12-4-N-UFK-4	HM-Wechselplatten / Carbide inserts / Plaquettes échangeables	12	14,5	4	UFK-4

3	Art. Nr. Item no. No. d'art.	Best. Nr. Ref. no. Réf.	Bezeichnung description désignation
		107349	Torx M3 x 8-T10

FHFPN-12-...-6-NF

max. Formtiefe: **t = 6,5 mm**
 max. depth of form: **t = 6,5 mm**
 max. profondeur de profil: **t = 6,5 mm**

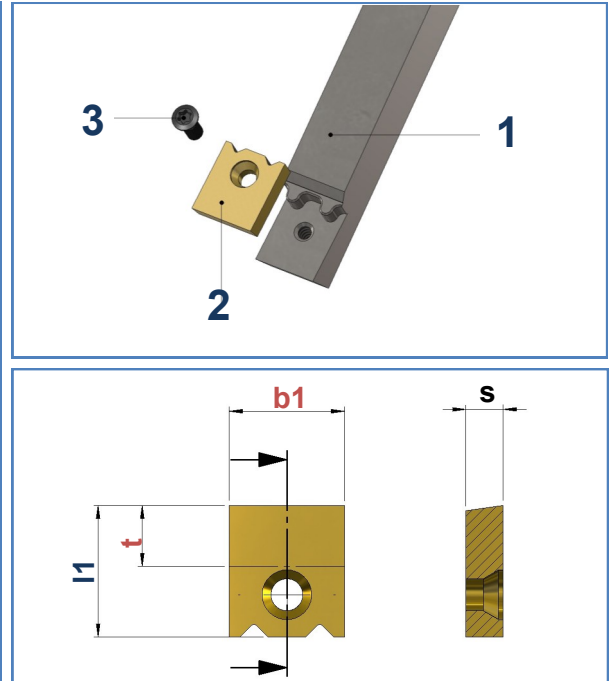
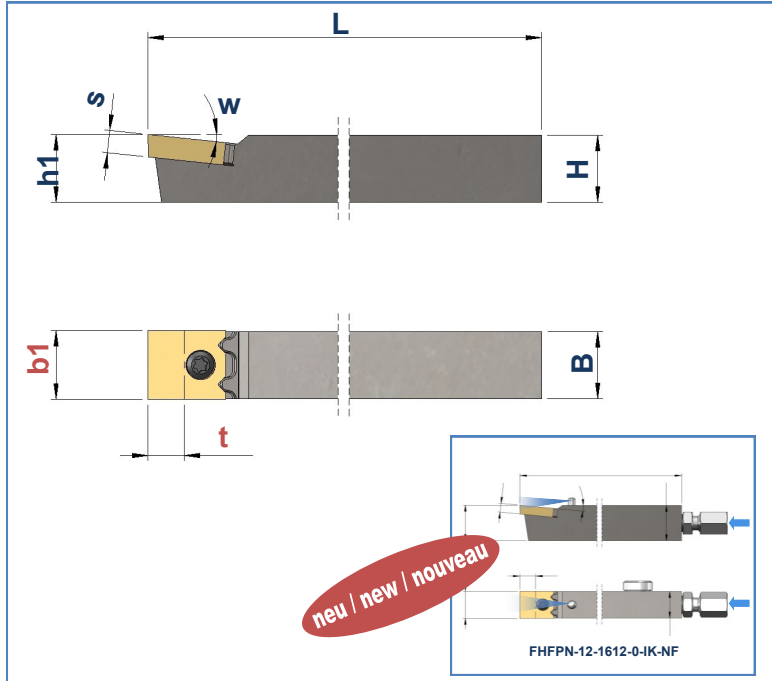

1	Art. Nr. Item no. No. d'art.	Best. Nr. Ref. no. Réf.	Bezeichnung description désignation	B	H	b1	h1	w	L
				mm	mm	mm	mm	mm	mm
	118174	FHFPN-12-1210-6-NF	Halter / Basic tool holder / Porte-outil de base	10	12	12	12	6°	140
	107286	FHFPN-12-1610-6-NF	Halter / Basic tool holder / Porte-outil de base	10	16	12	16	6°	125
	107287	FHFPN-12-2010-6-NF	Halter / Basic tool holder / Porte-outil de base	10	20	12	20	6°	125
	107289	FHFPN-12-1212-6-NF	Halter / Basic tool holder / Porte-outil de base	12	12	12	12	6°	140
	107290	FHFPN-12-1612-6-NF	Halter / Basic tool holder / Porte-outil de base	12	16	12	16	6°	125
	107291	FHFPN-12-2012-6-NF	Halter / Basic tool holder / Porte-outil de base	12	20	12	20	6°	125
	108657	FHFPN-12-2525-6-R	Halter / Basic tool holder / Porte-outil de base	25	25	12	25	6°	125
	163322	FHFPN-12-1212-6-IK-VR-NF	Halter / Basic tool holder / Porte-outil de base	12	12	12	12	6°	140
	125520	FHFPN-12-1612-6-IK-NF	Halter / Basic tool holder / Porte-outil de base	12	16	12	16	6°	140

2	Art. Nr. Item no. No. d'art.	Best. Nr. Ref. no. Réf.	Bezeichnung description désignation	b1	l1	S	HM-Sorte Carbide grade Nuance de carbure
				mm	mm	mm	
	107279	FPN-12-4-N-UFK-2	HM-Wechselplatten / Carbide inserts / Plaquettes échangeables	12	14,5	4	UFK-2
	107280	FPN-12-4-N-UFK-4	HM-Wechselplatten / Carbide inserts / Plaquettes échangeables	12	14,5	4	UFK-4

3	Art. Nr. Item no. No. d'art.	Best. Nr. Ref. no. Réf.	Bezeichnung description désignation
		107349	Torx M3 x 8-T10

FHFPN-16-...-NF

max. Formtiefe: **t = 9 mm**
 max. depth of form: **t = 9 mm**
 max. profondeur de profil: **t = 9 mm**

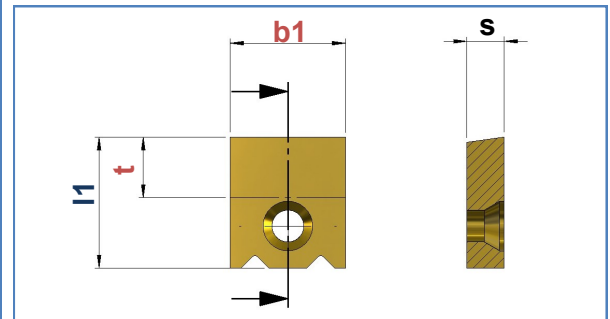
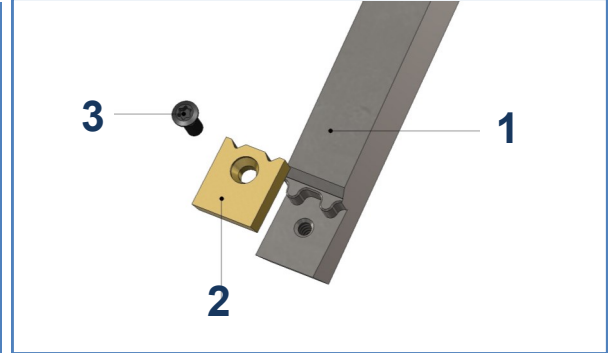
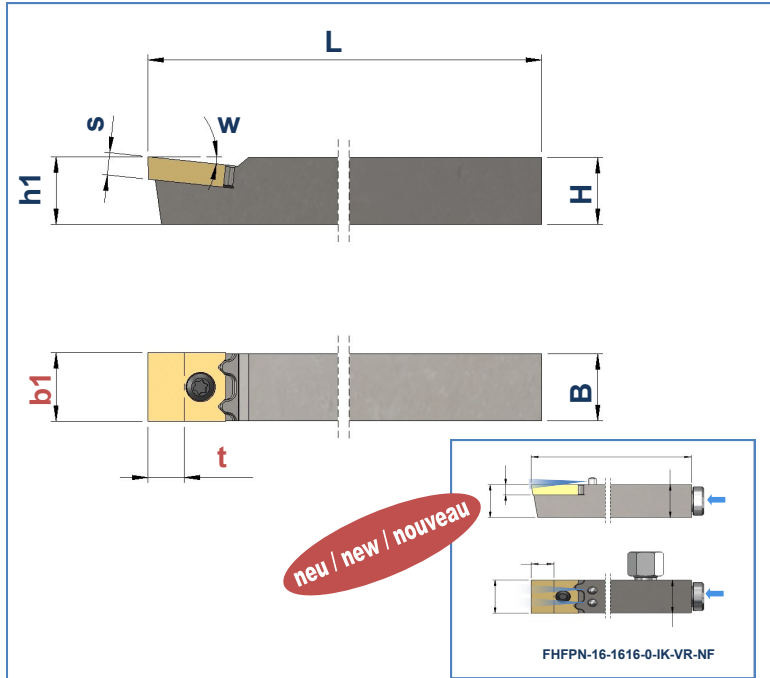

1	Art. Nr. Item no. No. d'art.	Best. Nr. Ref. no. Réf.	Bezeichnung description désignation	B	H	b1	h1	w	L
				mm	mm	mm	mm		mm
	107292	FHFPN-16-1216-0-NF	Halter / Basic tool holder / Porte-outil de base	16	12	16	12	0°	140
	107293	FHFPN-16-1616-0-NF	Halter / Basic tool holder / Porte-outil de base	16	16	16	16	0°	125
	108700	FHFPN-16-2016-0-NF	Halter / Basic tool holder / Porte-outil de base	16	20	16	20	0°	125
	107294	FHFPN-16-1616-6-NF	Halter / Basic tool holder / Porte-outil de base	16	16	16	16	6°	125
	107295	FHFPN-16-2016-6-NF	Halter / Basic tool holder / Porte-outil de base	16	20	16	20	6°	125
	123791	FHFPN-16-1616-0-VR-NF	Halter / Basic tool holder / Porte-outil de base	16	16	16	16	6°	140

2	Art. Nr. Item no. No. d'art.	Best. Nr. Ref. no. Réf.	Bezeichnung description désignation	b1	l1	S	HM-Sorte Carbide grade Nuance de carbure
				mm	mm	mm	
	107281	FPN-16-5-N-UFK-2	HM-Wechselplatten / Carbide inserts / Plaquettes échangeables	16	19	5	UFK-2
	107282	FPN-16-5-N-UFK-4	HM-Wechselplatten / Carbide inserts / Plaquettes échangeables	16	19	5	UFK-4

3	Art. Nr. Item no. No. d'art.	Best. Nr. Ref. no. Réf.	Bezeichnung description désignation
		102217	Torx M4 x 9,5-T15

FHFPN-20-...-NF

max. Formtiefe: **t = 9,5 mm**
 max. depth of form: **t = 9,5 mm**
 max. profondeur de profil: **t = 9,5 mm**

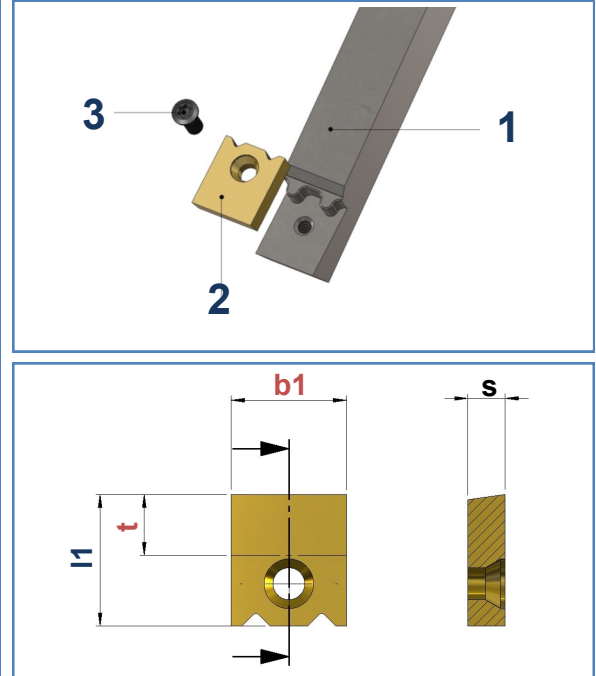
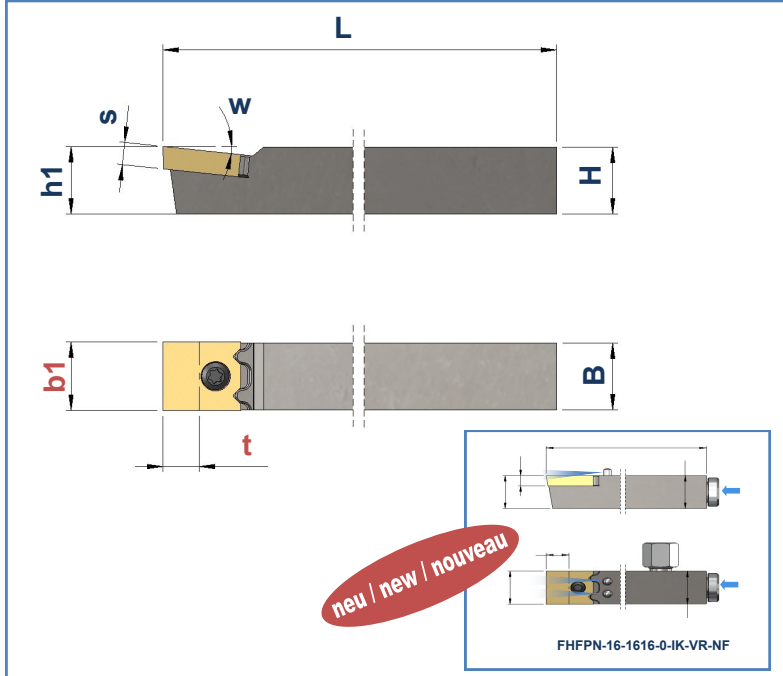

1	Art. Nr. Item no. No. d'art.	Best. Nr. Ref. no. Réf.	Bezeichnung description désignation	B	H	b1	h1	w	L
				mm	mm	mm	mm		mm
	107296	FHFPN-20-1220-0-NF	Halter / Basic tool holder / Porte-outil de base	20	12	20	12	0°	140
	108699	FHFPN-20-1620-0-NF	Halter / Basic tool holder / Porte-outil de base	20	16	20	16	0°	125
	107298	FHFPN-20-2020-0-NF	Halter / Basic tool holder / Porte-outil de base	20	20	20	20	0°	125
	107297	FHFPN-20-1620-6-NF	Halter / Basic tool holder / Porte-outil de base	20	16	20	16	6°	125
	107299	FHFPN-20-2020-6-NF	Halter / Basic tool holder / Porte-outil de base	20	20	20	20	6°	125
	108876	FHFPN-20-2020-10-NF	Halter / Basic tool holder / Porte-outil de base	20	20	20	20	10°	125
	123792	FHFPN-20-2020-0-IK-NF	Halter / Basic tool holder / Porte-outil de base	20	20	20	20	0°	125
	125294	FHFPN-20-2020-6-IK-NF	Halter / Basic tool holder / Porte-outil de base	20	20	20	20	6°	125

2	Art. Nr. Item no. No. d'art.	Best. Nr. Ref. no. Réf.	Bezeichnung description désignation	b1	l1	S	HM-Sorte Carbide grade Nuance de carbure
				mm	mm	mm	
	107283	FPN-20-5-N-UFK-2	HM-Wechselplatten / Carbide inserts / Plaquettes échangeables	20	21	5	UFK-2
	107284	FPN-20-5-N-UFK-4	HM-Wechselplatten / Carbide inserts / Plaquettes échangeables	20	21	5	UFK-4

3	Art. Nr. Item no. No. d'art.	Best. Nr. Ref. no. Réf.	Bezeichnung description désignation
		107278	Torx M5 x 10-T25

FHFPN-25-...-N

max. Formtiefe: **t = 9,5 mm**
 max. depth of form: **t = 9,5 mm**
 max. profondeur de profil: **t = 9,5 mm**

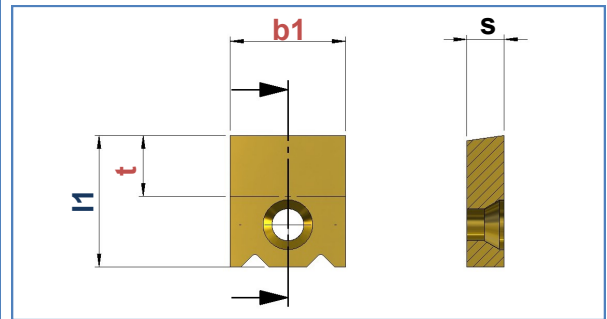
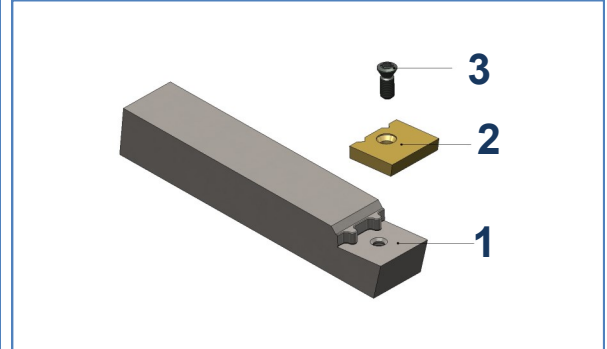
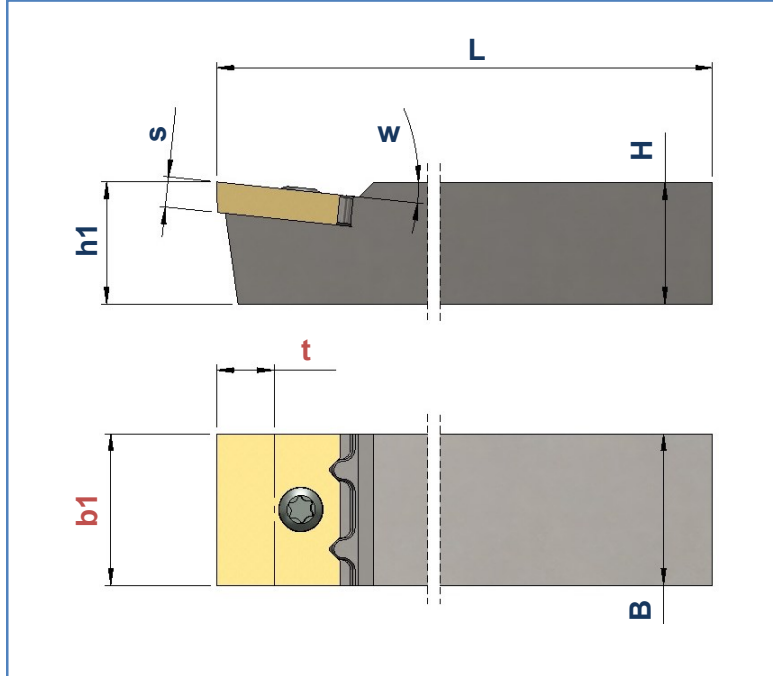

1	Art. Nr. Item no. No. d'art.	Best. Nr. Ref. no. Réf.	Bezeichnung description désignation	B	H	b1	h1	w	L
				mm	mm	mm	mm		mm
	160350	FHFPN-25-1625-0-N	Halter / Basic tool holder / Porte-outil de base	25	16	25	16	0°	125
	160349	FHFPN-25-2025-0-N	Halter / Basic tool holder / Porte-outil de base	25	20	25	20	0°	125
	160348	FHFPN-25-2525-0-N	Halter / Basic tool holder / Porte-outil de base	25	25	25	25	0°	125
	160353	FHFPN-25-1625-6-N	Halter / Basic tool holder / Porte-outil de base	25	16	25	16	6°	125
	160352	FHFPN-25-2025-6-N	Halter / Basic tool holder / Porte-outil de base	25	20	25	20	6°	125
	160351	FHFPN-25-2525-6-N	Halter / Basic tool holder / Porte-outil de base	25	25	25	25	6°	125

2	Art. Nr. Item no. No. d'art.	Best. Nr. Ref. no. Réf.	Bezeichnung description désignation	b1	l1	S	HM-Sorte Carbide grade Nuance de carbure
				mm	mm	mm	
	155227	FPN-25-5-N-UFK-4	HM-Wechselplatten / Carbide inserts / Plaquettes échangeables	25	21	5	UFK-4

3	Art. Nr. Item no. No. d'art.	Best. Nr. Ref. no. Réf.	Bezeichnung description désignation
		102219	Torx M5 x 13-T25

FHFPN-25-...-IK- N

neu / new / nouveau

max. Formtiefe: $t = 9,5$ mm
 max. depth of form: $t = 9,5$ mm
 max. profondeur de profil: $t = 9,5$ mm

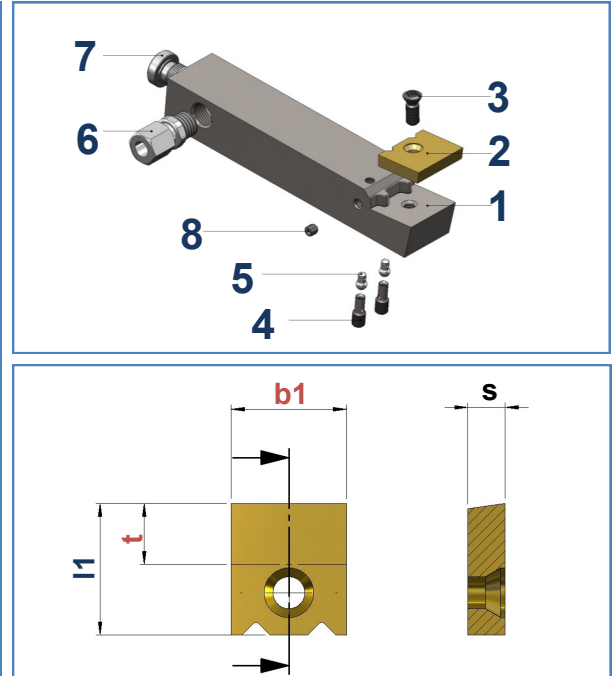
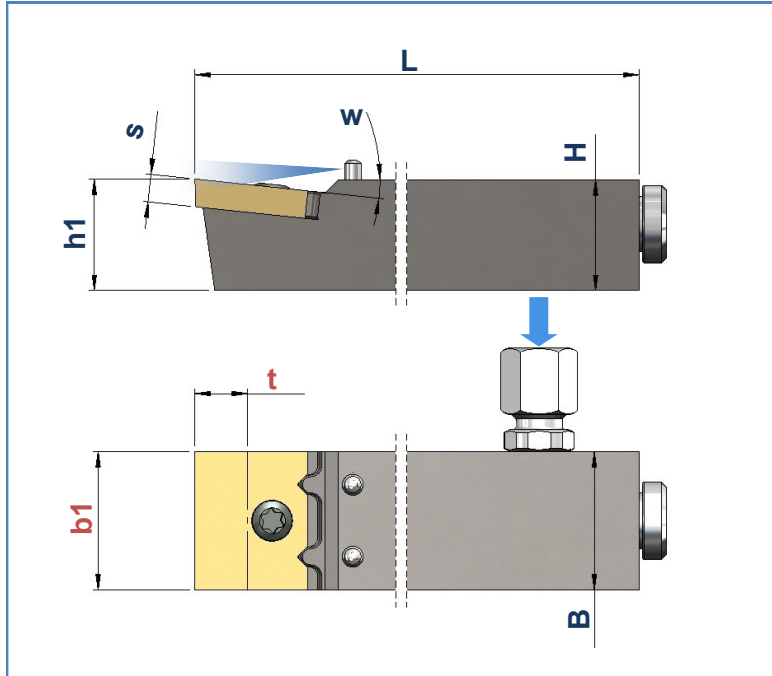

1	Art. Nr. Item no. No. d'art.	Best. Nr. Ref. no. Réf.	Bezeichnung description désignation	B	H	b1	h1	w	L
				mm	mm	mm	mm		mm
	160356	FHFPN-25-1625-0-IK-VR-N	Halter / Basic tool holder / Porte-outil de base	25	16	25	16	0°	125
	160355	FHFPN-25-2025-0-IK-VR-N	Halter / Basic tool holder / Porte-outil de base	25	20	25	20	0°	125
	160354	FHFPN-25-2525-0-IK-VR-N	Halter / Basic tool holder / Porte-outil de base	25	25	25	25	0°	125
	160359	FHFPN-25-1625-6-IK-VR-N	Halter / Basic tool holder / Porte-outil de base	25	16	25	16	6°	125
	160358	FHFPN-25-2025-6-IK-VR-N	Halter / Basic tool holder / Porte-outil de base	25	20	25	20	6°	125
	160357	FHFPN-25-2525-6-IK-VR-N	Halter / Basic tool holder / Porte-outil de base	25	25	25	25	6°	125

2	Art. Nr. Item no. No. d'art.	Best. Nr. Ref. no. Réf.	Bezeichnung description désignation	b1	l1	S	HM-Sorte Carbide grade Nuance de carbure
				mm	mm	mm	
	155227	FPN-25-5-N-UFK-4	HM-Wechselplatten / Carbide inserts / Plaquettes échangeables	25	21	5	UFK-4

	Art. Nr. Item no. No. d'art.	Best. Nr. Ref. no. Réf.	Bezeichnung description désignation
3	102219	Torx M5 x 13-T25	Spannschraube / Fixing screw / Vis de fixation
4	125415	KS-16	Klemmschraube / Fixing screw / Vis de fixation
5	126018	KD-42-U	Kühlmitteldüse / coolant nozzle / buse d'arrosage
6	125585	GE-06-PLM-ED-CF-M10X1	Gerade Einschraubverschraubung / straight screw-in connection / raccord droit
7	125584	VSTI-M10X1-ED-CF	Verschluss-Stopfen / plug / bouchon
8	102216	M4 x 4 DIN 913 SW2	Gewindestift / threaded pin / tige filetée

FHFP-11-...

max. Formtiefe: **t = 5 mm**
 max. depth of form: **t = 5 mm**
 max. profondeur de profil: **t = 5 mm**

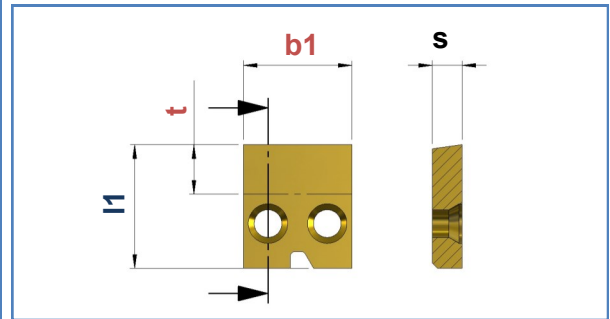
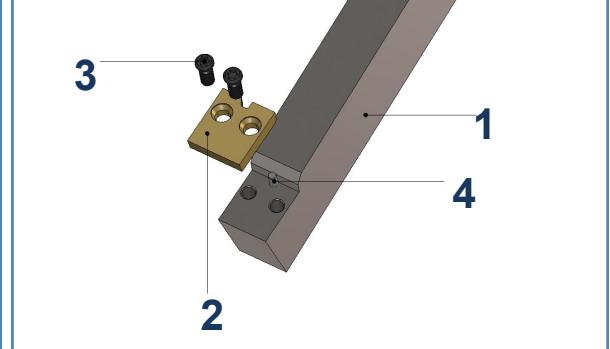
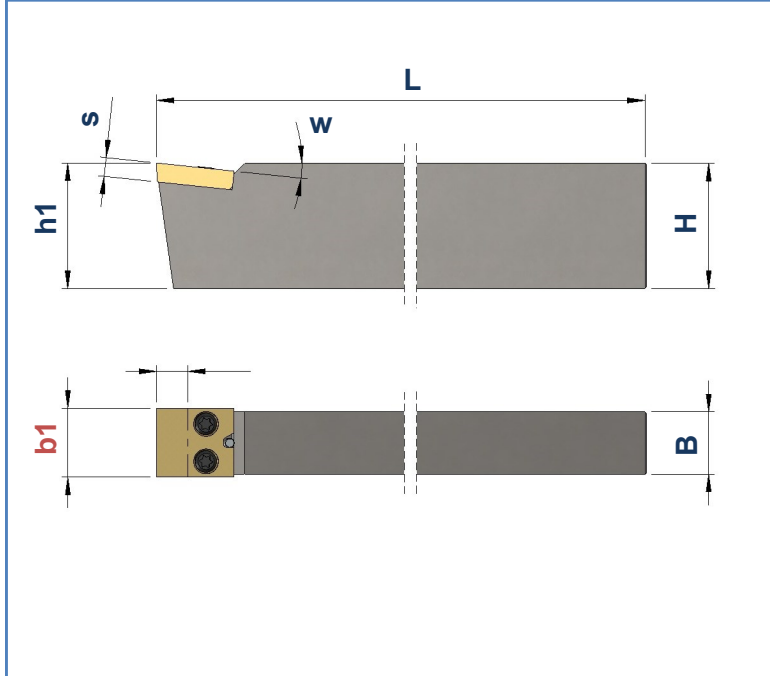

1	Art. Nr. Item no. No. d'art.	Best. Nr. Ref. no. Réf.	Bezeichnung description désignation	B	H	b1	h1	w	L
				mm	mm	mm	mm		mm
	101340	FHFP-11-1010-140-0	Halter / Basic tool holder / Porte-outil de base	10	10	11	10	0°	140
	101343	FHFP-11-1210-140-0	Halter / Basic tool holder / Porte-outil de base	10	12	11	12	0°	140
	101346	FHFP-11-1610-125-0	Halter / Basic tool holder / Porte-outil de base	10	16	11	16	0°	125
	101348	FHFP-11-2010-125-0	Halter / Basic tool holder / Porte-outil de base	10	20	11	20	0°	125
	101341	FHFP-11-1010-140-4	Halter / Basic tool holder / Porte-outil de base	10	10	11	10	4°	140
	101345	FHFP-11-1210-150-4	Halter / Basic tool holder / Porte-outil de base	10	12	11	12	4°	140
	101342	FHFP-11-1010-140-6	Halter / Basic tool holder / Porte-outil de base	10	10	11	10	6°	140
	101344	FHFP-11-1210-140-6	Halter / Basic tool holder / Porte-outil de base	10	12	11	12	6°	140
	101347	FHFP-11-1610-125-6	Halter / Basic tool holder / Porte-outil de base	10	16	11	16	6°	125
	101349	FHFP-11-2010-125-6	Halter / Basic tool holder / Porte-outil de base	10	20	11	20	6°	125

2	Art. Nr. Item no. No. d'art.	Best. Nr. Ref. no. Réf.	Bezeichnung description désignation	b1	l1	S	HM-Sorte Carbide grade Nuance de carbure
				mm	mm	mm	
	101518	FP-11-FK	HM-Wechselplatten / Carbide inserts / Plaquettes échangeables	11	12,5	3	FK
	101519	FP-11-K10	HM-Wechselplatten / Carbide inserts / Plaquettes échangeables	11	12,5	3	K10

3	Art. Nr. Item no. No. d'art.	Best. Nr. Ref. no. Réf.	Bezeichnung description désignation
		102206	Torx M2,5 x 7-T7
4	103960	Ø1,5m6 x 8- DIN 6325	Zylinderstift / Dowel / Goujon de butée

FHFP-11-5...

max. Formtiefe: **t = 5 mm**
 max. depth of form: **t = 5 mm**
 max. profondeur de profil: **t = 5 mm**

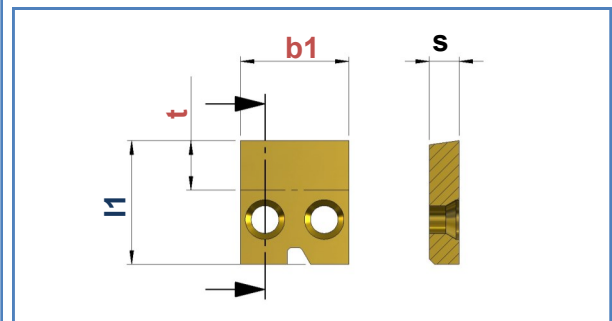
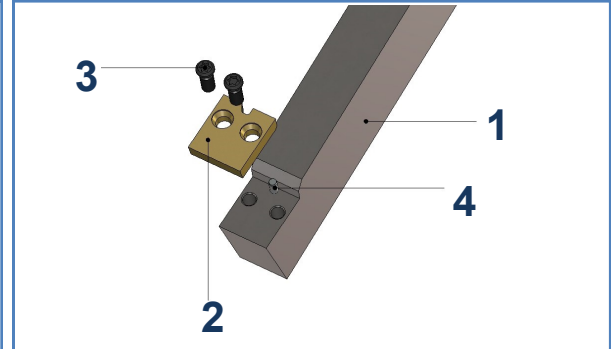
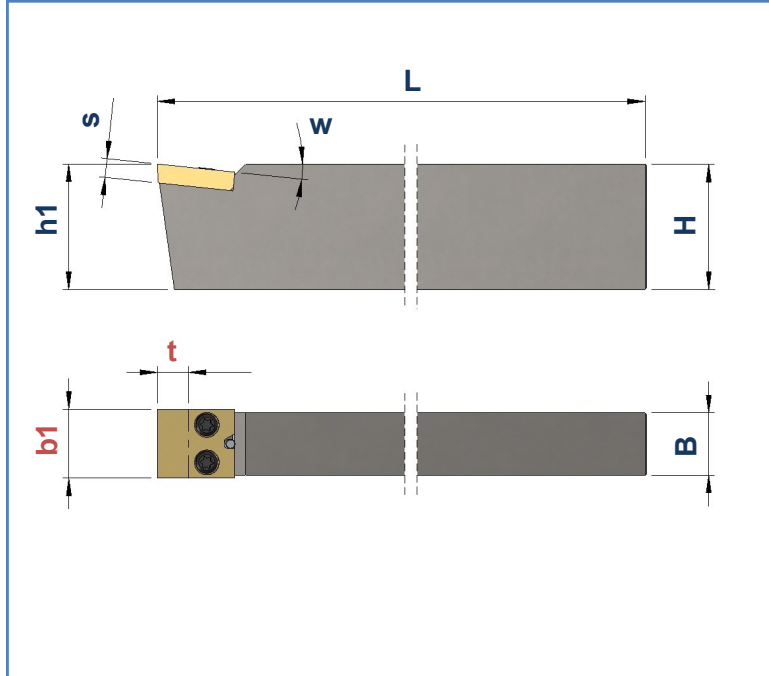

	Art. Nr. Item no. No. d'art.	Best. Nr. Ref. no. Réf.	Bezeichnung description désignation	B	H	b1	h1	w	L
				mm	mm	mm	mm		mm
1	101350	FHFP-11-5-1210-125-0	Halter / Basic tool holder / Porte-outil de base	10	12	11	12	0°	140
	101351	FHFP-11-5-1610-125-0	Halter / Basic tool holder / Porte-outil de base	10	16	11	16	0°	125
	101353	FHFP-11-5-2010-125-0	Halter / Basic tool holder / Porte-outil de base	10	20	11	20	0°	125
	101352	FHFP-11-5-1610-125-6	Halter / Basic tool holder / Porte-outil de base	10	16	11	16	6°	125
	101354	FHFP-11-5-2010-125-6	Halter / Basic tool holder / Porte-outil de base	10	20	11	20	6°	125

	Art. Nr. Item no. No. d'art.	Best. Nr. Ref. no. Réf.	Bezeichnung description désignation	b1	l1	S	HM-Sorte Carbide grade Nuance de carbure
				mm	mm	mm	
2	101522	FP-11-5-FK	HM-Wechselplatten / Carbide inserts / Plaquettes échangeables	11	12,5	5	FK
	101523	FP-11-5-K10	HM-Wechselplatten / Carbide inserts / Plaquettes échangeables	11	12,5	5	K10

	Art. Nr. Item no. No. d'art.	Best. Nr. Ref. no. Réf.	Bezeichnung description désignation
3	102207	M-2.5X10-T7	Spannschraube / Fixing screw / Vis de fixation
4	107608	Ø1,5m6 x 10- DIN 6325	Zylinderstift/ Dowel / Goujon de butée

FHFP-13-...

max. Formtiefe: **t = 5 mm**
 max. depth of form: **t = 5 mm**
 max. profondeur de profil: **t = 5 mm**

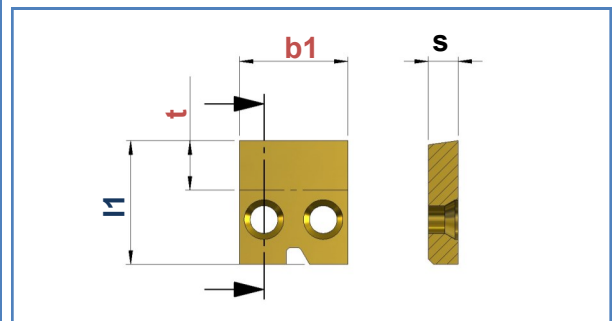
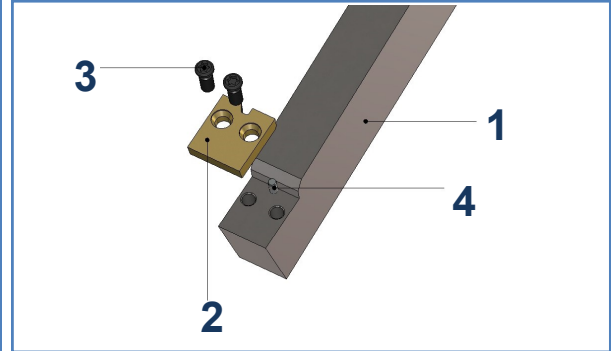
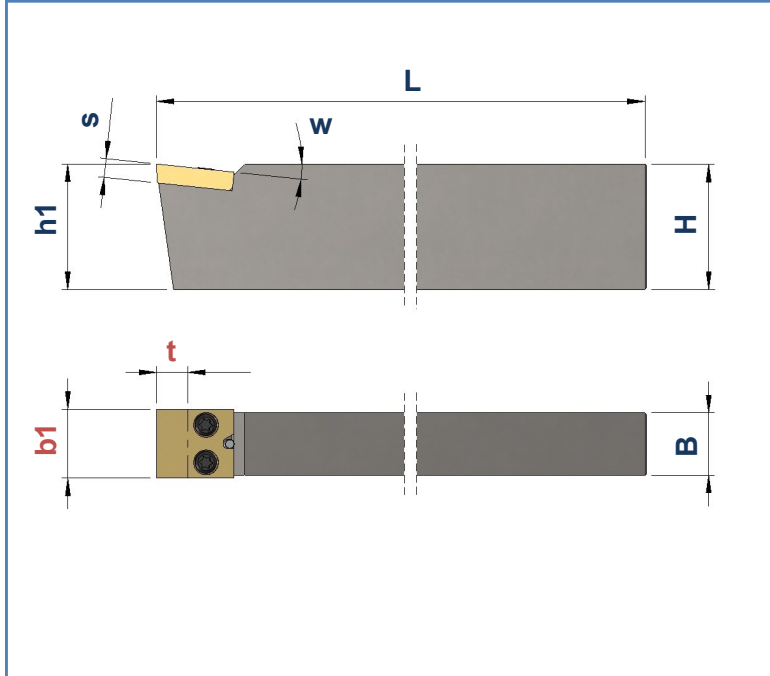

1	Art. Nr. Item no. No. d'art.	Best. Nr. Ref. no. Réf.	Bezeichnung description désignation	B	H	b1	h1	w	L
				mm	mm	mm	mm		mm
	101355	FHFP-13-1012-140-0	Halter / Basic tool holder / Porte-outil de base	12	10	13	10	0°	140
	101358	FHFP-13-1212-140-0	Halter / Basic tool holder / Porte-outil de base	12	12	13	12	0°	140
	101360	FHFP-13-1412-150-0	Halter / Basic tool holder / Porte-outil de base	12	14	13	14	0°	150
	101363	FHFP-13-1612-125-0	Halter / Basic tool holder / Porte-outil de base	12	16	13	16	0°	125
	101365	FHFP-13-2012-125-0	Halter / Basic tool holder / Porte-outil de base	12	20	13	20	0°	125
	101362	FHFP-13-1414-150-0	Halter / Basic tool holder / Porte-outil de base	14	14	13	14	0°	150
	101356	FHFP-13-1012-150-4	Halter / Basic tool holder / Porte-outil de base	12	10	13	10	4°	150

2	Art. Nr. Item no. No. d'art.	Best. Nr. Ref. no. Réf.	Bezeichnung description désignation	b1	l1	S	HM-Sorte Carbide grade Nuance de carbure
				mm	mm	mm	
	101527	FP-13-K10	HM-Wechselplatten / Carbide inserts / Plaquettes échangeables	13	12,5	3	K10
	101526	FP-13-FK-30	HM-Wechselplatten / Carbide inserts / Plaquettes échangeables	13	12,5	3	FK

3	Art. Nr. Item no. No. d'art.	Best. Nr. Ref. no. Réf.	Bezeichnung description désignation
		102206	Torx M2,5 x 7-T7
4	103960	Ø1,5m6 x 8- DIN 6325	Zylinderstift/ Dowel / Goujon de butée

FHFP-13-...6°

max. Formtiefe: **t = 5 mm**
 max. depth of form: **t = 5 mm**
 max. profondeur de profil: **t = 5 mm**

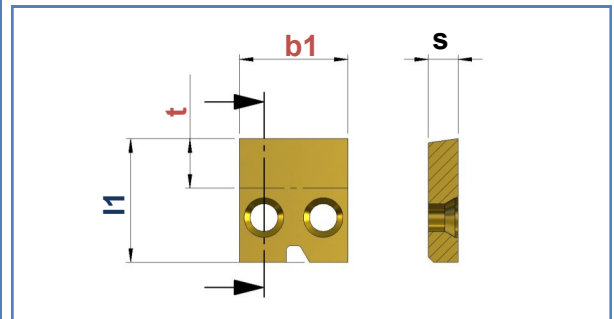
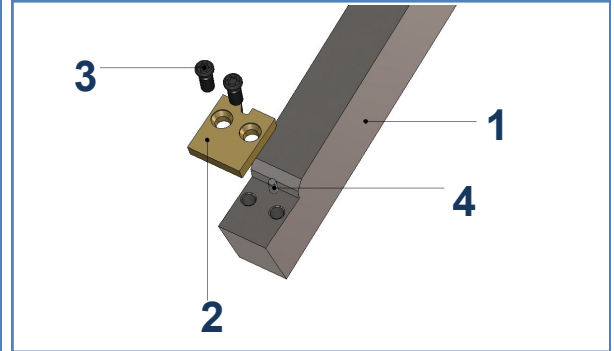
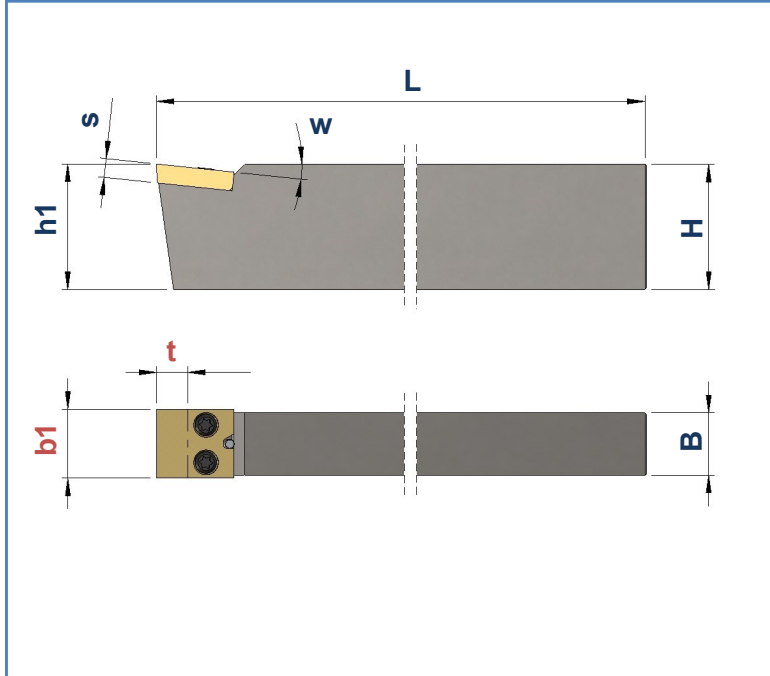

1	Art. Nr. Item no. No. d'art.	Best. Nr. Ref. no. Réf.	Bezeichnung description désignation	B	H	b1	h1	w	L
				mm	mm	mm	mm		mm
	101357	FHFP-13-1012-150-6	Halter / Basic tool holder / Porte-outil de base	12	10	13	10	6°	140
	101359	FHFP-13-1212-140-6	Halter / Basic tool holder / Porte-outil de base	12	12	13	12	6°	140
	101361	FHFP-13-1412-150-6	Halter / Basic tool holder / Porte-outil de base	12	14	13	14	6°	150
	101364	FHFP-13-1612-125-6	Halter / Basic tool holder / Porte-outil de base	12	16	13	16	6°	125
	101366	FHFP-13-2012-125-6	Halter / Basic tool holder / Porte-outil de base	12	20	13	20	6°	125
	101367	FHFP-13-2012-125-12	Halter / Basic tool holder / Porte-outil de base	12	20	13	20	12°	125

2	Art. Nr. Item no. No. d'art.	Best. Nr. Ref. no. Réf.	Bezeichnung description désignation	b1	l1	S	HM-Sorte Carbide grade Nuance de carbure
				mm	mm	mm	
	101527	FP-13-K10	HM-Wechselplatten / Carbide inserts / Plaquettes échangeables	13	12,5	3	K10
	101526	FP-13-FK-30	HM-Wechselplatten / Carbide inserts / Plaquettes échangeables	13	12,5	3	FK

3	Art. Nr. Item no. No. d'art.	Best. Nr. Ref. no. Réf.	Bezeichnung description désignation
		102206	Torx M2,5 x 7-T7
4	103960	Ø1,5m6 x 8- DIN 6325	Zylinderstift / Dowel / Goujon de butée

FHFP-13-5-...

max. Formtiefe: **t = 5 mm**
 max. depth of form: **t = 5 mm**
 max. profondeur de profil: **t = 5 mm**

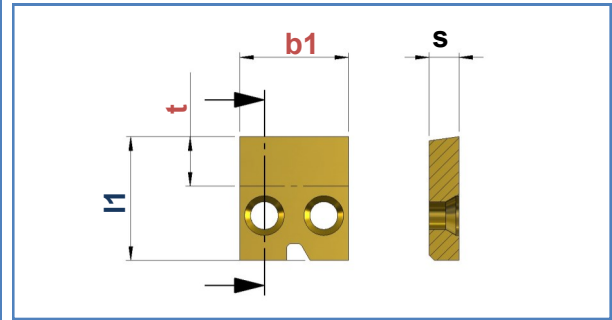
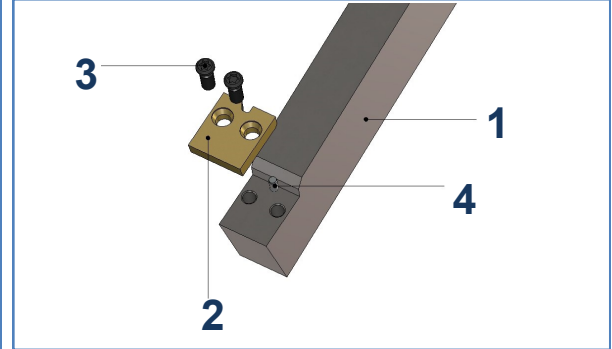
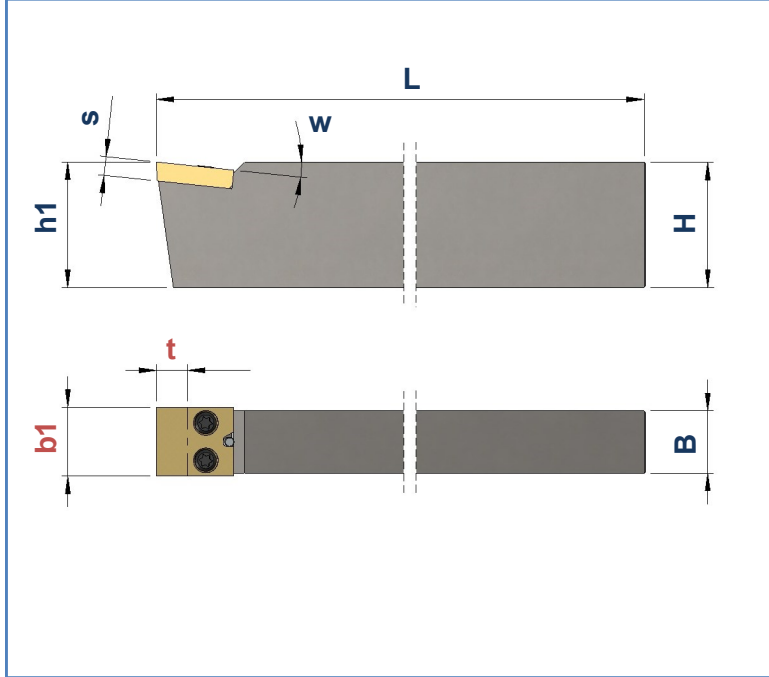

1	Art. Nr. Item no. No. d'art.	Best. Nr. Ref. no. Réf.	Bezeichnung description désignation	B	H	b1	h1	w	L
	mm	mm	mm	mm	mm	mm	mm	mm	mm
	101368	FHFP-13-5-1612-125-0	Halter / Basic tool holder / Porte-outil de base	12	16	13	16	0°	125
	101370	FHFP-13-5-2012-125-0	Halter / Basic tool holder / Porte-outil de base	12	20	13	20	0°	125
	101369	FHFP-13-5-1612-125-6	Halter / Basic tool holder / Porte-outil de base	12	16	13	16	6°	125
	101371	FHFP-13-5-2012-125-6	Halter / Basic tool holder / Porte-outil de base	12	20	13	20	6°	125

2	Art. Nr. Item no. No. d'art.	Best. Nr. Ref. no. Réf.	Bezeichnung description désignation	b1	l1	S	HM-Sorte Carbide grade Nuance de carbure
	mm	mm	mm	mm	mm	mm	
	101531	FP-13-5-K10	HM-Wechselplatten / Carbide inserts / Plaquettes échangeables	13	12,5	5	K10
	101530	FP-13-5-FK-30	HM-Wechselplatten / Carbide inserts / Plaquettes échangeables	13	12,5	5	FK

3	Art. Nr. Item no. No. d'art.	Best. Nr. Ref. no. Réf.	Bezeichnung description désignation
		102207	M-2.5X10-T7

4	Art. Nr. Item no. No. d'art.	Best. Nr. Ref. no. Réf.	Bezeichnung description désignation
		107608	Ø1,5m6 x 10- DIN 6325

FHFP-16-...

max. Formtiefe: **t = 8 mm**
 max. depth of form: **t = 8 mm**
 max. profondeur de profil: **t = 8 mm**

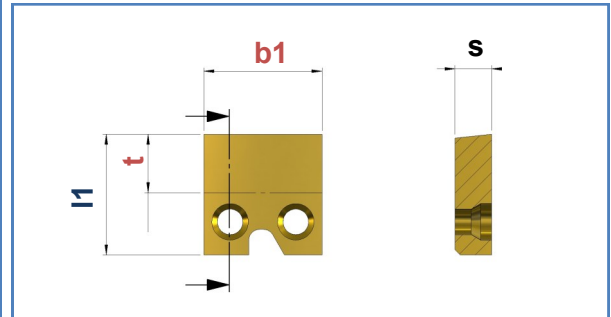
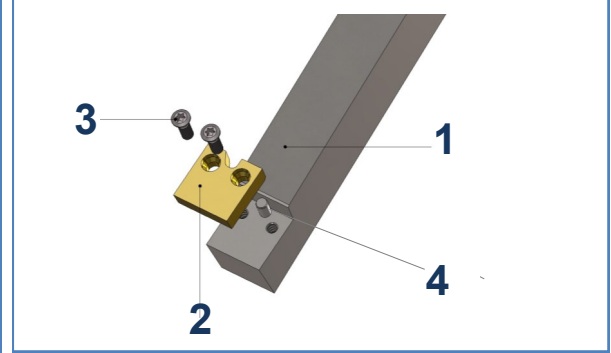
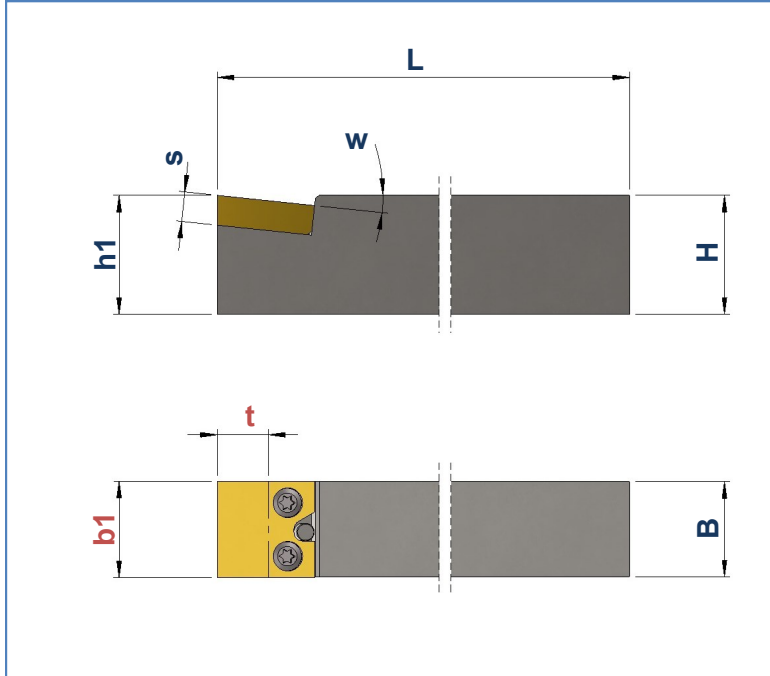

1	Art. Nr. Item no. No. d'art.	Best. Nr. Ref. no. Réf.	Bezeichnung description désignation	B	H	b1	h1	w	L
				mm	mm	mm	mm		mm
	101372	FHFP-16-1016-140-0	Halter / Basic tool holder / Porte-outil de base	16	10	16	10	0°	140
	101373	FHFP-16-1216-140-0	Halter / Basic tool holder / Porte-outil de base	16	12	16	12	0°	140
	101377	FHFP-16-1616-125-0	Halter / Basic tool holder / Porte-outil de base	16	16	16	16	0°	125
	101380	FHFP-16-2016-125-0	Halter / Basic tool holder / Porte-outil de base	16	20	16	20	0°	125
	101382	FHFP-16-2016-150-4	Halter / Basic tool holder / Porte-outil de base	16	20	16	20	4°	150
	101374	FHFP-16-1216-140-6	Halter / Basic tool holder / Porte-outil de base	16	12	16	12	6°	140
	101378	FHFP-16-1616-125-6	Halter / Basic tool holder / Porte-outil de base	16	16	16	16	6°	125
	101381	FHFP-16-2016-125-6	Halter / Basic tool holder / Porte-outil de base	16	20	16	20	6°	125
	119012	FHFP-16-1616-125-12	Halter / Basic tool holder / Porte-outil de base	16	16	16	16	12°	125

2	Art. Nr. Item no. No. d'art.	Best. Nr. Ref. no. Réf.	Bezeichnung description désignation	b1	l1	S	HM-Sorte Carbide grade Nuance de carbure
				mm	mm	mm	
	101536	FP-16-K10	HM-Wechselplatten / Carbide inserts / Plaquettes échangeables	16	16,5	5	K10
	101535	FP-16-FK-30	HM-Wechselplatten / Carbide inserts / Plaquettes échangeables	16	16,5	5	FK

	Art. Nr. Item no. No. d'art.	Best. Nr. Ref. no. Réf.	Bezeichnung description désignation
3	102209	M-3X10-T9	Spannschraube / Fixing screw / Vis de fixation
4	103964	Ø3m6 x 10- DIN 6325	Zylinderstift / Dowel / Goujon de butée

FHFP-20-...

max. Formtiefe: **t = 8,5 mm**
 max. depth of form: **t = 8,5 mm**
 max. profondeur de profil: **t = 8,5 mm**

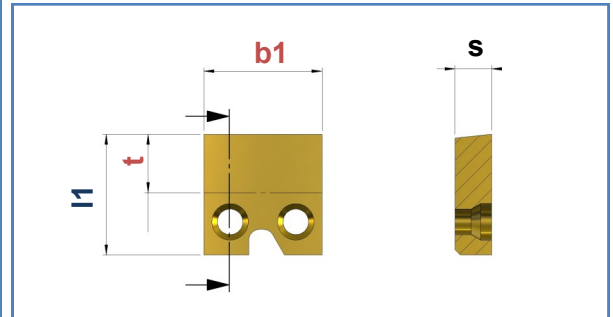
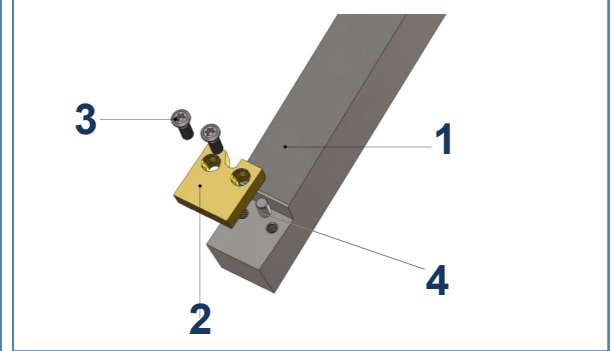
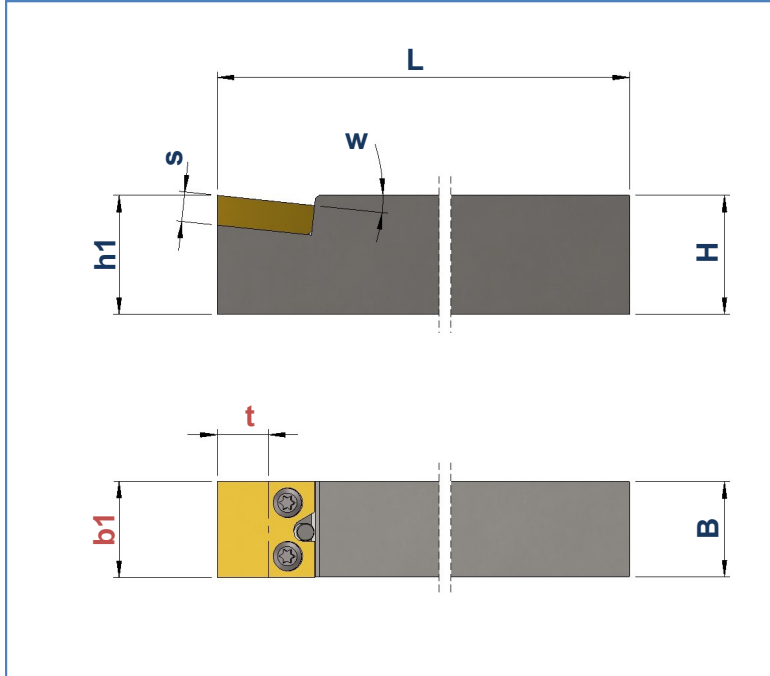

1	Art. Nr. Item no. No. d'art.	Best. Nr. Ref. no. Réf.	Bezeichnung description désignation	B	H	b1	h1	w	L
				mm	mm	mm	mm		mm
	101383	FHFP-20-1020-140-0	Halter / Basic tool holder / Porte-outil de base	20	10	20	10	0°	140
	101385	FHFP-20-1220-140-0	Halter / Basic tool holder / Porte-outil de base	20	12	20	12	0°	140
	101387	FHFP-20-1420-125-0	Halter / Basic tool holder / Porte-outil de base	20	14	20	14	0°	125
	101389	FHFP-20-1620-125-0	Halter / Basic tool holder / Porte-outil de base	20	16	20	20	0°	125
	101393	FHFP-20-2020-125-0	Halter / Basic tool holder / Porte-outil de base	20	20	20	20	0°	125
	101386	FHFP-20-1220-140-6	Halter / Basic tool holder / Porte-outil de base	20	12	20	12	6°	140
	101390	FHFP-20-1620-125-6	Halter / Basic tool holder / Porte-outil de base	20	16	20	20	6°	125
	101394	FHFP-20-2020-125-6	Halter / Basic tool holder / Porte-outil de base	20	20	20	20	6°	125
	120926	FHFP-20-2020-125-12	Halter / Basic tool holder / Porte-outil de base	20	20	20	20	12°	125

2	Art. Nr. Item no. No. d'art.	Best. Nr. Ref. no. Réf.	Bezeichnung description désignation	b1	l1	S	HM-Sorte Carbide grade Nuance de carbure
				mm	mm	mm	
	101540	FP-20-K10	HM-Wechselplatten / Carbide inserts / Plaquettes échangeables	20	17	5	K10
	101539	FP-20-FK-30	HM-Wechselplatten / Carbide inserts / Plaquettes échangeables	20	17	5	FK

3	Art. Nr. Item no. No.	Best. Nr. Ref. no. Réf.	Bezeichnung description désignation
		102209	M-3X10-T9
4	103964	Ø3m6 x 10- DIN 6325	Zylinderstift / Dowel / Goujon de butée

FHFP-25-...

max. Formtiefe: **t = 11 mm**
 max. depth of form: **t = 11 mm**
 max. profondeur de profil: **t = 11 mm**

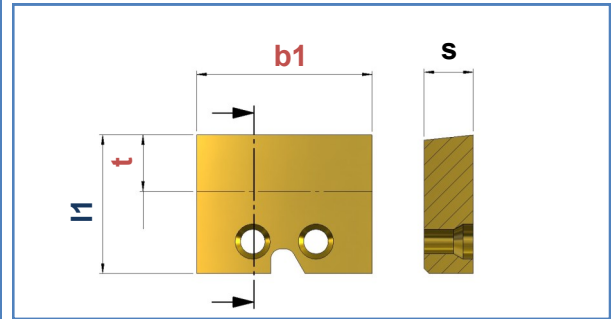
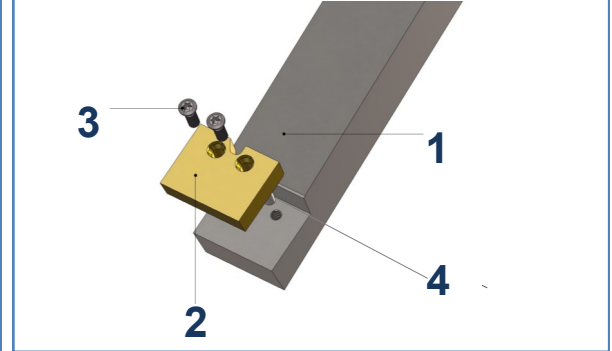
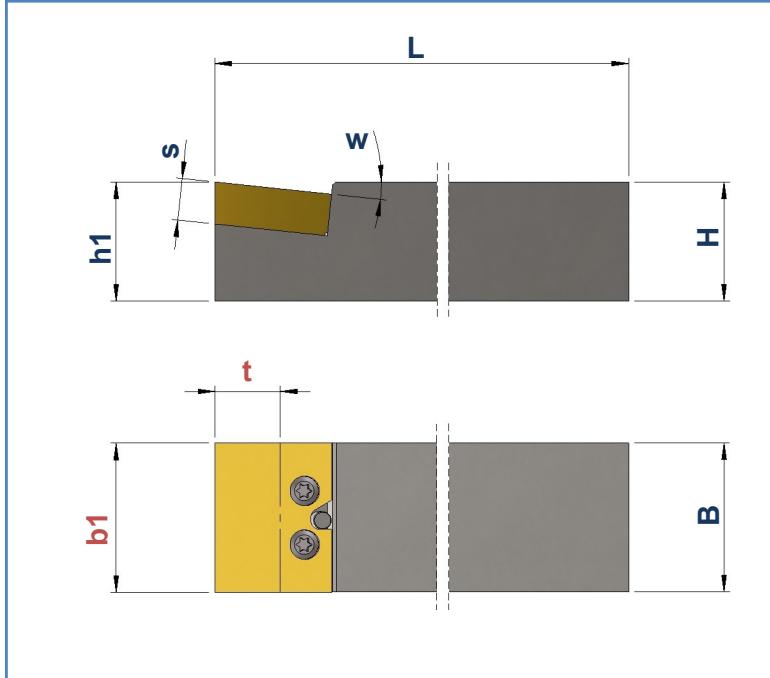

1	Art. Nr. Item no. No. d'art.	Best. Nr. Ref. no. Réf.	Bezeichnung description désignation	B	H	b1	h1	w	L
	mm	mm	mm	mm	mm	mm	mm	mm	mm
	101397	FHFP-25-1625-125-0	Halter / Basic tool holder / Porte-outil de base	25	16	25	16	0°	125
	101399	FHFP-25-2025-125-0	Halter / Basic tool holder / Porte-outil de base	25	20	25	20	0°	125
	101398	FHFP-25-1625-125-6	Halter / Basic tool holder / Porte-outil de base	25	16	25	16	6°	125
	101400	FHFP-25-2025-125-6	Halter / Basic tool holder / Porte-outil de base	25	20	25	20	6°	125

2	Art. Nr. Item no. No. d'art.	Best. Nr. Ref. no. Réf.	Bezeichnung description désignation	b1	l1	S	HM-Sorte Carbide grade Nuance de carbure
	mm	mm	mm	mm	mm	mm	
	101544	FP-25-K10	HM-Wechselplatten / Carbide inserts / Plaquettes échangeables	25	19,7	7	K10
	101543	FP-25-FK-30	HM-Wechselplatten / Carbide inserts / Plaquettes échangeables	25	19,7	7	FK

3	Art. Nr. Item no. No. d'art.	Best. Nr. Ref. no. Réf.	Bezeichnung description désignation
		102209	M-3X10-T9
4	Art. Nr. Item no. No. d'art.	Best. Nr. Ref. no. Réf.	Bezeichnung description désignation
		103964	Ø3m6 x 10- DIN 6325

FHFP-30-...

max. Formtiefe: **t = 11 mm**
 max. depth of form: **t = 11 mm**
 max. profondeur de profil: **t = 11 mm**

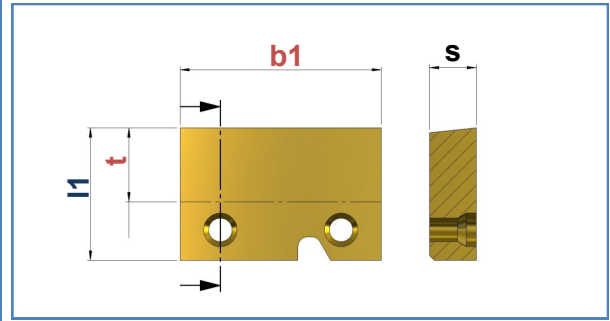
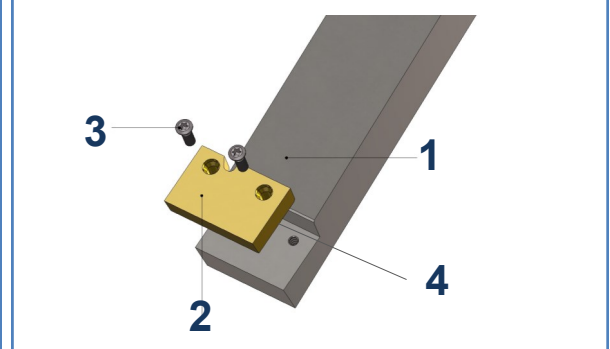
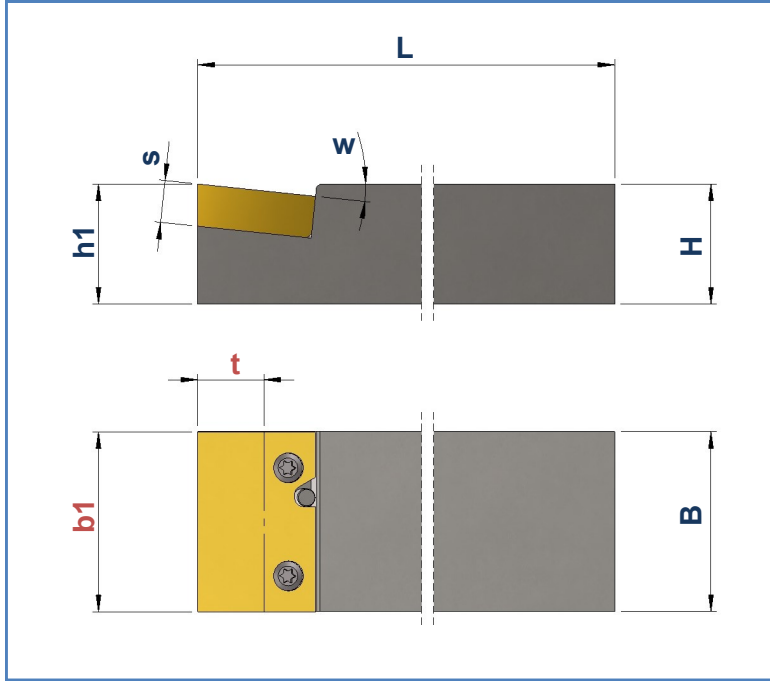

1	Art. Nr. Item no. No. d'art.	Best. Nr. Ref. no. Réf.	Bezeichnung description désignation	B	H	b1	h1	w	L
	mm	mm	mm	mm	mm	mm	mm	mm	mm
	101401	FHFP-30-1630-125-0	Halter / Basic tool holder / Porte-outil de base	30	16	30	16	0°	125
	101403	FHFP-30-2030-125-0	Halter / Basic tool holder / Porte-outil de base	30	20	30	20	0°	125
	101402	FHFP-30-1630-125-6	Halter / Basic tool holder / Porte-outil de base	30	16	30	16	6°	125
	101404	FHFP-30-2030-125-6	Halter / Basic tool holder / Porte-outil de base	30	20	30	20	6°	125

2	Art. Nr. Item no. No. d'art.	Best. Nr. Ref. no. Réf.	Bezeichnung description désignation	b1	l1	S	HM-Sorte Carbide grade Nuance de carbure
	mm	mm	mm	mm	mm	mm	
	101548	FP-30-K10	HM-Wechselplatten / Carbide inserts / Plaquettes échangeables	30	19,7	7	K10
	101547	FP-30-FK-30	HM-Wechselplatten / Carbide inserts / Plaquettes échangeables	30	19,7	7	FK

3	Art. Nr. Item no. No. d'art.	Best. Nr. Ref. no. Réf.	Bezeichnung description désignation
		102209	M-3X10-T9
4	103965	Ø3m6 x 12- DIN 6325	Zylinderstift / Dowel / Goujon de butée

FHEB-16-...

max. Formtiefe: **t = 4 mm**
 max. depth of form: **t = 4 mm**
 max. profondeur de profil: **t = 4 mm**

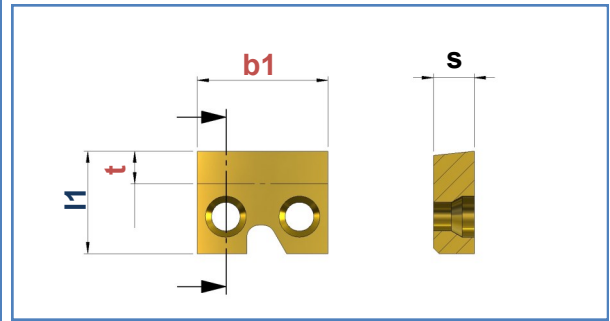
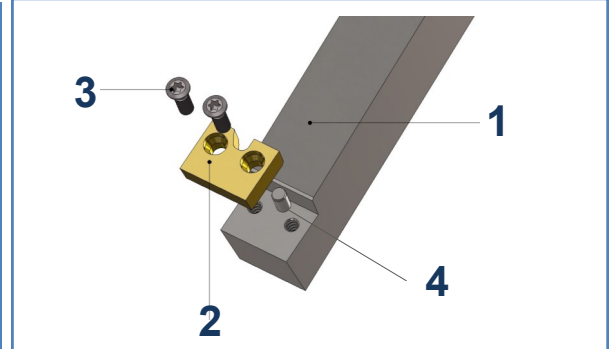
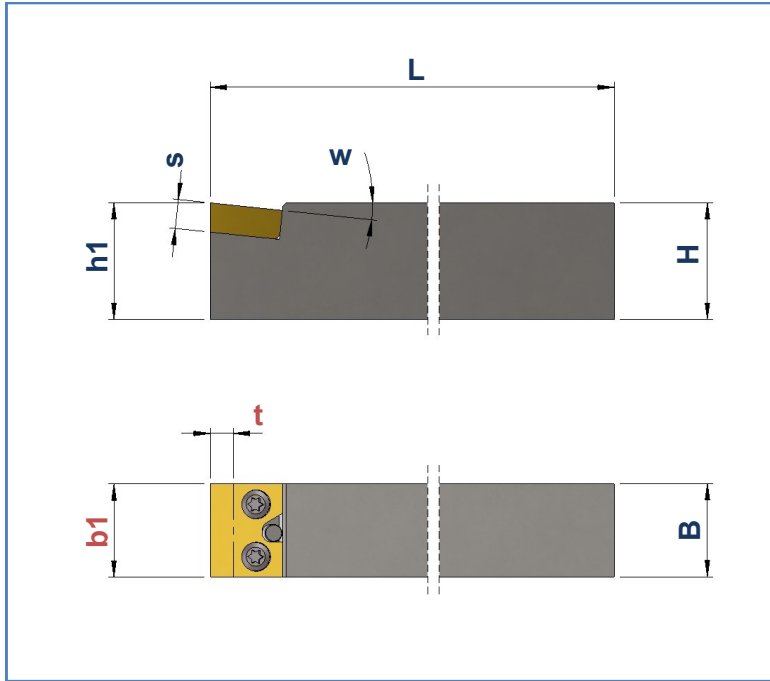

1	Art. Nr. Item no. No. d'art.	Best. Nr. Ref. no. Réf.	Bezeichnung description désignation	B	H	b1	h1	w	L
	mm	mm	mm	mm	mm	mm	mm	mm	mm
	101321	FHEB-16-1016-140-0	Halter / Basic tool holder / Porte-outil de base	16	10	16	10	0°	140
	101322	FHEB-16-1216-140-0	Halter / Basic tool holder / Porte-outil de base	16	12	16	12	0°	140
	101324	FHEB-16-1414-150-0	Halter / Basic tool holder / Porte-outil de base	14	14	16	14	0°	150
	101325	FHEB-16-1416-150-0	Halter / Basic tool holder / Porte-outil de base	16	14	16	14	0°	150
	101328	FHEB-16-1616-125-0	Halter / Basic tool holder / Porte-outil de base	16	16	16	16	0°	125
	101330	FHEB-16-2016-125-0	Halter / Basic tool holder / Porte-outil de base	16	20	16	20	0°	125
	101323	FHEB-16-1216-140-6	Halter / Basic tool holder / Porte-outil de base	16	12	16	12	6°	140
	101326	FHEB-16-1416-150-6	Halter / Basic tool holder / Porte-outil de base	16	14	16	14	6°	150
	101329	FHEB-16-1616-125-6	Halter / Basic tool holder / Porte-outil de base	16	16	16	16	6°	125
	101331	FHEB-16-2016-125-6	Halter / Basic tool holder / Porte-outil de base	16	20	16	20	0°	125
	101327	FHEB-16-1416-150-8	Halter / Basic tool holder / Porte-outil de base	16	14	16	14	8°	150

2	Art. Nr. Item no. No. d'art.	Best. Nr. Ref. no. Réf.	Bezeichnung description désignation	b1	l1	S	HM-Sorte Carbide grade Nuance de carbure
	mm	mm	mm	mm	mm	mm	
	101193	EB-16-K10	HM-Wechselplatten / Carbide inserts / Plaquettes échangeables	16	12,5	5	K10
	101192	EB-16-FK-30	HM-Wechselplatten / Carbide inserts / Plaquettes échangeables	16	12,5	5	FK

3	Art. Nr. Item no. No. d'art.	Best. Nr. Ref. no. Réf.	Bezeichnung description désignation
		102209	M-3X10-T9
4	103964	Ø3m6 x 10- DIN 6325	Zylinderstift / Dowel / Goujon de butée

FHEB-25-...

max. Formtiefe: **t = 4 mm**
 max. depth of form: **t = 4 mm**
 max. profondeur de profil: **t = 4 mm**

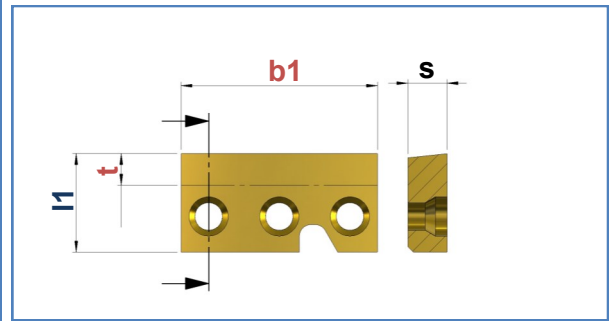
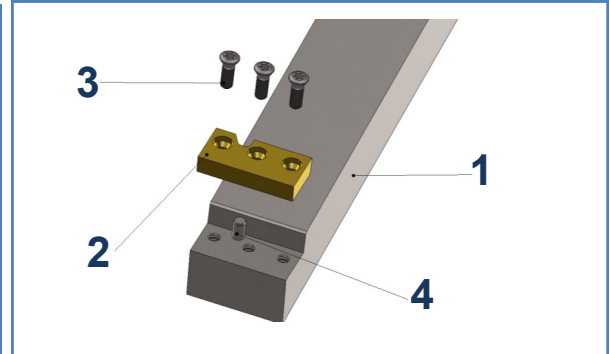
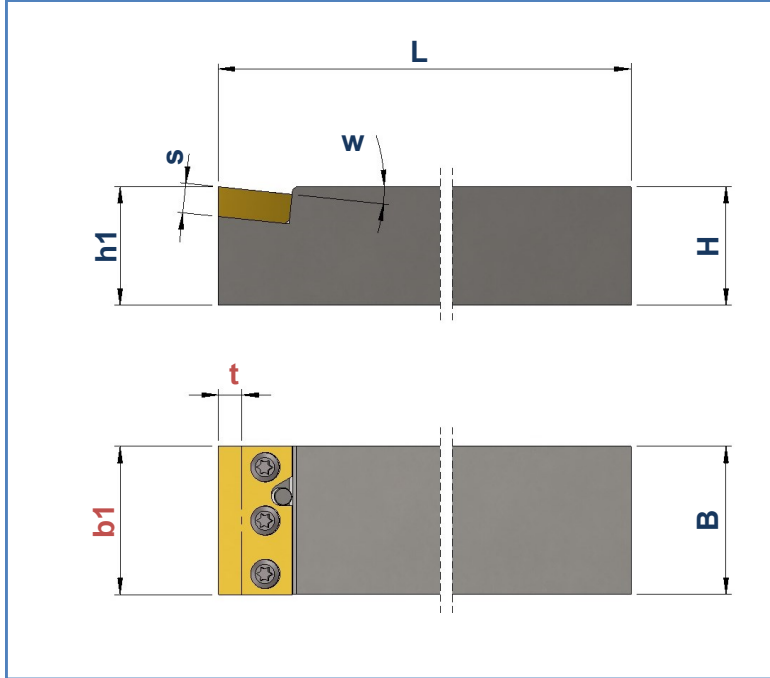

Art. Nr. Item no. No. d'art.	Best. Nr. Ref. no. Réf.	Bezeichnung description désignation	B mm	H mm	b1 mm	h1 mm	w	L mm	
1	101332	FHEB-25-1025-140-0	Halter / Basic tool holder / Porte-outil de base	25	10	25	10	0°	140
	101333	FHEB-25-1225-140-0	Halter / Basic tool holder / Porte-outil de base	25	12	25	12	0°	140
	101335	FHEB-25-1425-140-0	Halter / Basic tool holder / Porte-outil de base	25	14	25	14	0°	140
	101336	FHEB-25-1625-125-0	Halter / Basic tool holder / Porte-outil de base	25	16	25	16	0°	125
	101338	FHEB-25-2025-125-0	Halter / Basic tool holder / Porte-outil de base	25	20	25	20	0°	125
	101334	FHEB-25-1225-140-6	Halter / Basic tool holder / Porte-outil de base	25	12	25	12	6°	140
	101337	FHEB-25-1625-125-6	Halter / Basic tool holder / Porte-outil de base	25	16	25	16	6°	125
	101339	FHEB-25-2025-125-6	Halter / Basic tool holder / Porte-outil de base	25	20	25	20	6°	125

Art. Nr. Item no. No. d'art.	Best. Nr. Ref. no. Réf.	Bezeichnung description désignation	b1 mm	l1 mm	S mm	HM-Sorte Carbide grade Nuance de carbure	
2	101197	EB-25-K10	HM-Wechselplatten / Carbide inserts / Plaquettes échangeables	25	12,5	5	K10
	101196	EB-25-FK-30	HM-Wechselplatten / Carbide inserts / Plaquettes échangeables	25	12,5	5	FK

Art. Nr. Item no. No. d'art.	Best. Nr. Ref. no. Réf.	Bezeichnung description désignation	
3	102209	M-3X10-T9	Spannschraube / Fixing screw / Vis de fixation
	103964	Ø3m6 x 10- DIN 6325	Zylinderstift / Dowel / Goujon de butée

FHFPT-20-2020-0-N

max. Formtiefe: $t = 17 \text{ mm}$
 max. depth of form: $t = 17 \text{ mm}$
 max. profondeur de profil: $t = 17 \text{ mm}$

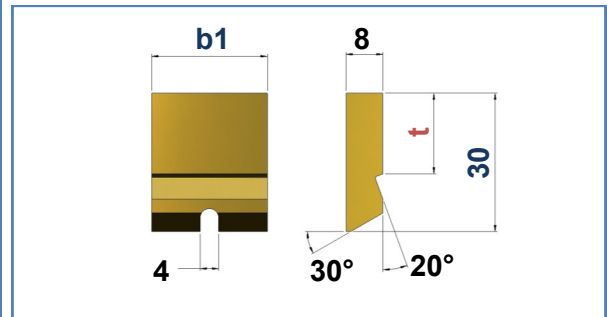
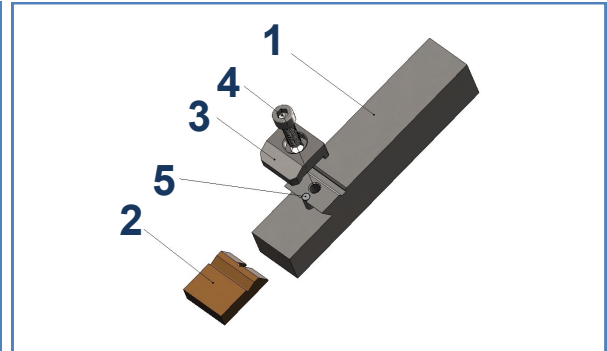
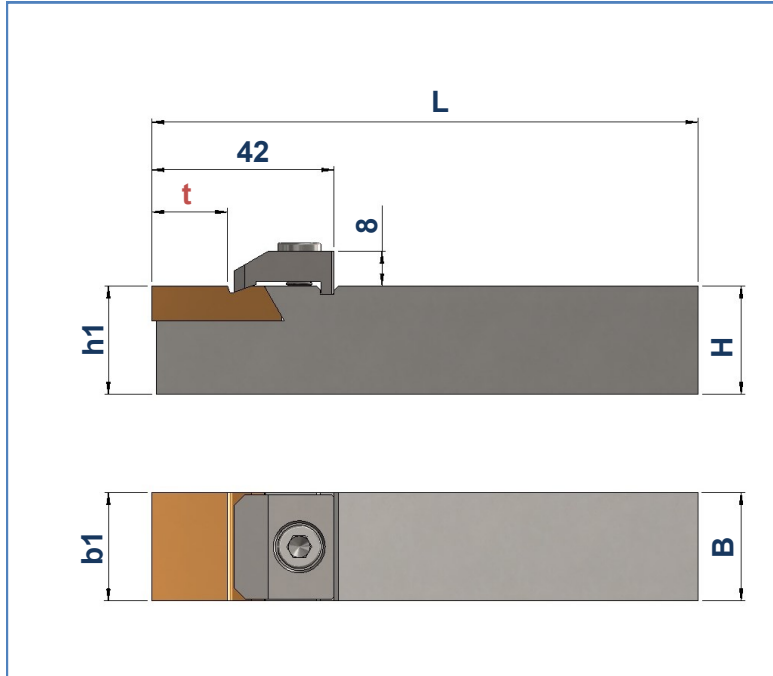

1	Art. Nr. Item no. No. d'art.	Best. Nr. Ref. no. Réf.	Bezeichnung description désignation	B mm	H mm	b1 mm	h1 mm	L mm
	118341	FHFPT-20-2020-0-N	Halter / Basic tool holder / Porte-outil de base	20	20	20	20	125

2	Art. Nr. Item no. No. d'art.	Best. Nr. Ref. no. Réf.	Bezeichnung description désignation	b1 mm	HM-Sorte Carbide grade Nuance de
	119287	FPT-20-8-N-FK-30	HM-Wechselplatten / Carbide inserts / Plaquettes échangeables	20	FK

	Art. Nr. Item no. No. d'art.	Best. Nr. Ref. no. Réf.	Bezeichnung description désignation
3	118344	FPK-20-N	Klemme/Clamp/Mors de serrage
4	107680	M6 x 20-DIN 912-SW5	Spannschraube / Fixing screw / Vis de fixation
5	111081	Ø4 _{m6} x 16- DIN 6325	Anschlagstift / Dowel / Goujon de butée

FHFPT-25-2525-0-N

max. Formtiefe: $t = 17$ mm
 max. depth of form: $t = 17$ mm
 max. profondeur de profil: $t = 17$ mm

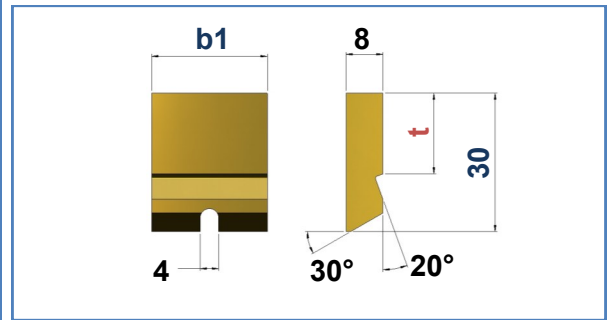
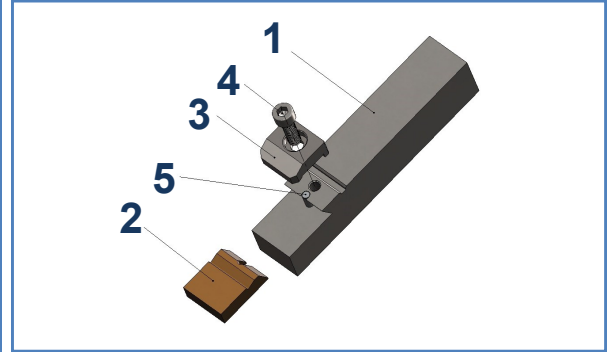
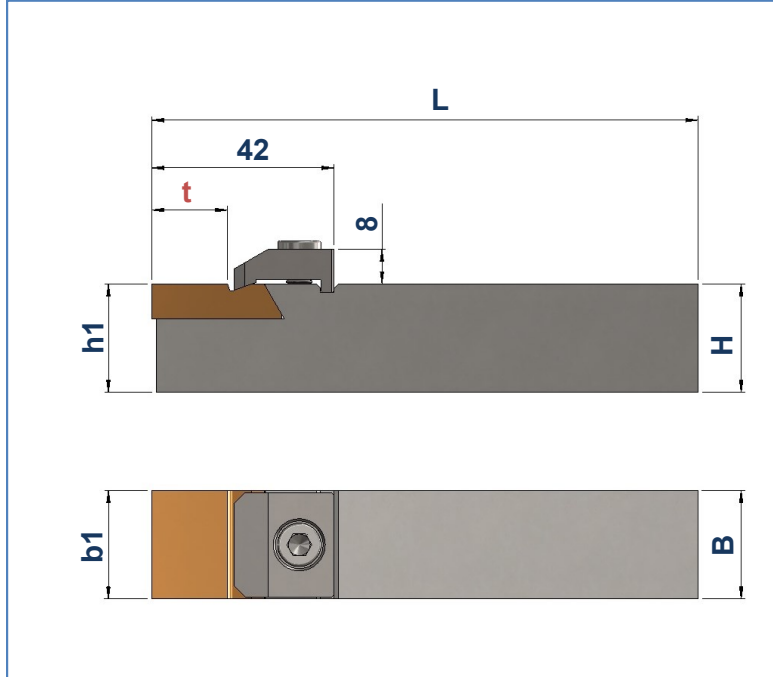

1	Art. Nr. Item no. No. d'art.	Best. Nr. Ref. no. Réf.	Bezeichnung description désignation	B mm	H mm	b1 mm	h1 mm	L mm
	118366	FHFPT-25-2525-0-N	Halter / Basic tool holder / Porte-outil de base	25	25	25	25	125

2	Art. Nr. Item no. No. d'art.	Best. Nr. Ref. no. Réf.	Bezeichnung description désignation	b1 mm	HM-Sorte Carbide grade Nuance de
	119288	FPT-25-8-N-FK-30	HM-Wechselplatten / Carbide inserts / Plaquettes échangeables	25	FK

	Art. Nr. Item no. No. d'art.	Best. Nr. Ref. no. Réf.	Bezeichnung description désignation
3	118365	FPK-25-N	Klemme/Clamp/Mors de serrage
4	107680	M6 x 20-DIN 912-SW5	Spannschraube / Fixing screw / Vis de fixation
5	111081	Ø4m6 x 16- DIN 6325	Anschlagstift / Dowel / Goujon de butée

FHFPT-32-3232-0-N

max. Formtiefe: **t = 17 mm**
 max. depth of form: **t = 17 mm**
 max. profondeur de profil: **t = 17 mm**

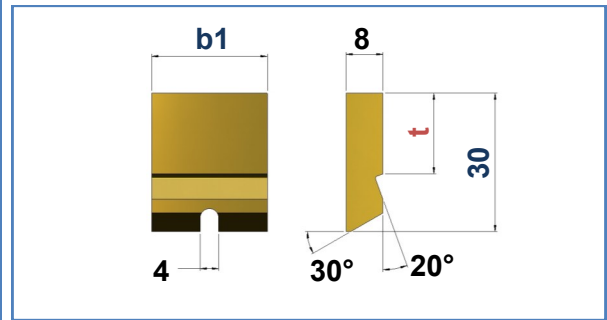
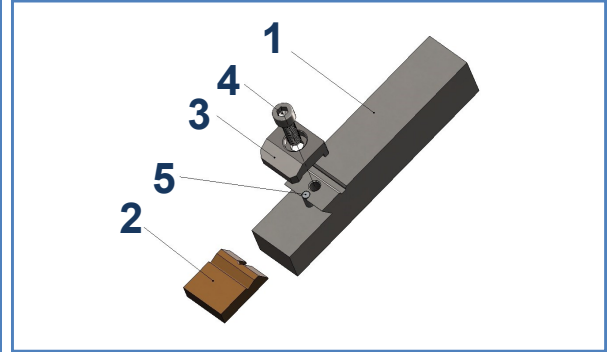
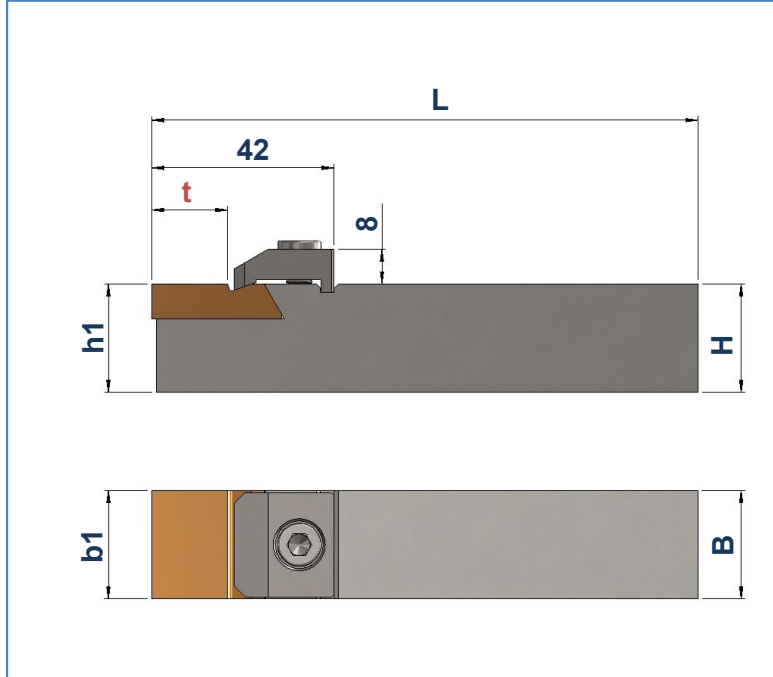

1	Art. Nr. Item no. No. d'art.	Best. Nr. Ref. no. Réf.	Bezeichnung description désignation	B mm	H mm	b1 mm	h1 mm	L mm
	118364	FHFPT-32-3232-0-N	Halter / Basic tool holder / Porte-outil de base	32	32	32	32	125

2	Art. Nr. Item no. No. d'art.	Best. Nr. Ref. no. Réf.	Bezeichnung description désignation	b1 mm	HM-Sorte Carbide grade Nuance de
	119659	FPT-32-8-N-FK-30	HM-Wechselplatten / Carbide inserts / Plaquettes échangeables	32	FK

	Art. Nr. Item no. No. d'art.	Best. Nr. Ref. no. Réf.	Bezeichnung description désignation
3	118363	FPK-32-N	Klemme/Clamp/Mors de serrage
4	107680	M6 x 20-DIN 912-SW5	Spannschraube / Fixing screw / Vis de fixation
5	111081	Ø4 _{m6} x 16- DIN 6325	Anschlagstift / Dowel / Goujon de butée

F-BFH-20

max. Formtiefe: **t = 9 mm**
 max. depth of form: **t = 9 mm**
 max. profondeur de profil: **t = 9 mm**

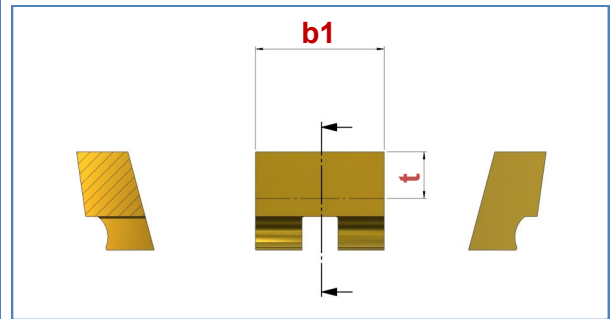
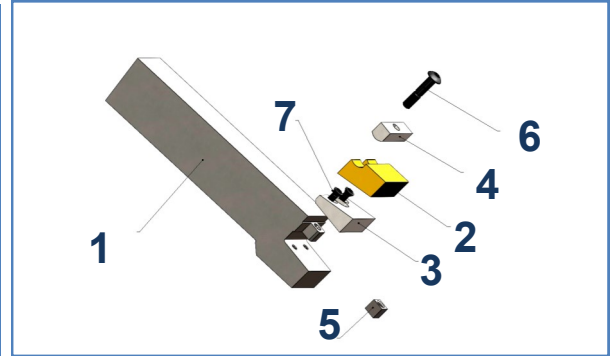
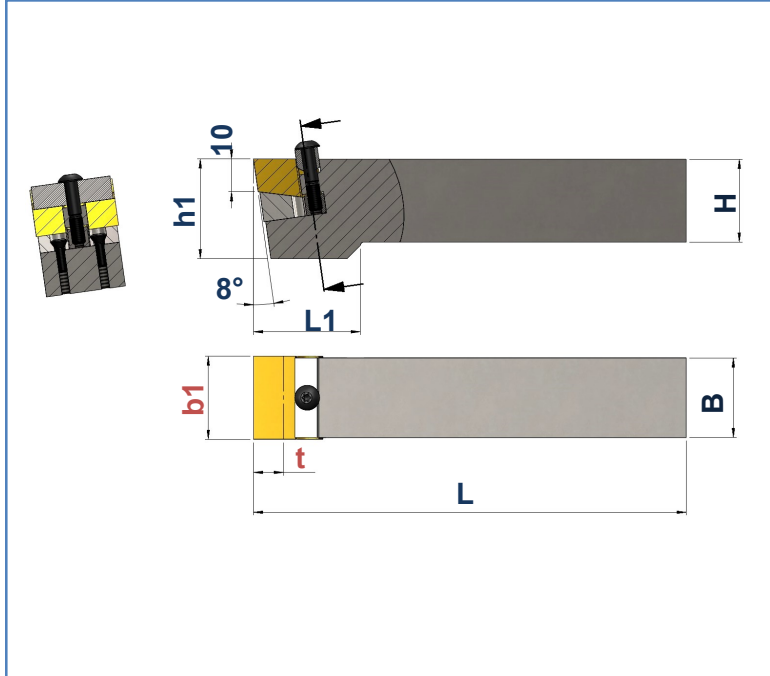

1	Art. Nr. Item no. No. d'art.	Best. Nr. Ref. no. Réf.	Bezeichnung description désignation	B mm	H mm	b1 mm	h1 mm	L mm	L1 mm
	101252	F-BFH-20-20-N	Halter / Basic tool holder / Porte-outil de base	19	20	20	30	130	32
	101255	F-BFH-20-25-N	Halter / Basic tool holder / Porte-outil de base	19	25	20	30	130	32

	Art. Nr. Item no. No. d'art.	Best. Nr. Ref. no. Réf.	Bezeichnung description désignation	b1 mm	HM-Sorte Carbide grade Nuance de carbure
2	100670	BFP-20-FK	HM-Wechselplatten / Carbide inserts / Plaquettes échangeables	20	FK
	100671	BFP-20-K10			K10
3	101990	I-GP-20	Grundplatte/ Support blade / Plaque de base		
4	102098	KL-20	Klemme/Clamp/Mors de serrage		
5	101681	GS-4	Gewindestück / threaded bush / pièce filetée		
6	103429	SP-19 Torx T15	Spannschraube / Fixing screw / Vis de fixation		
7	107349	M3x8 T10	Spannschraube / Fixing screw / Vis de fixation		

F-BFH-25

max. Formtiefe: **t = 9 mm**
 max. depth of form: **t = 9 mm**
 max. profondeur de profil: **t = 9 mm**

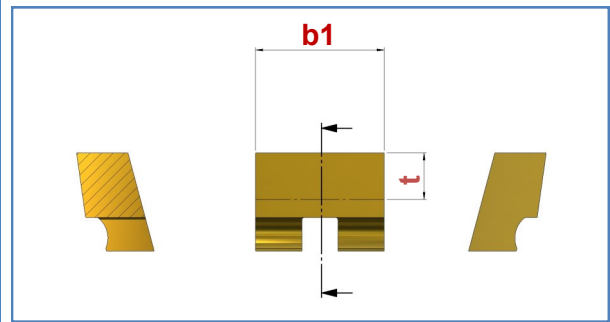
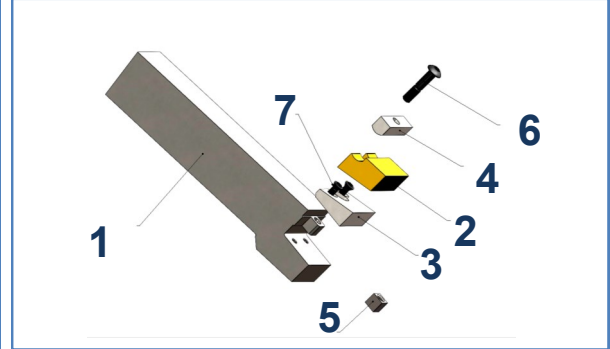
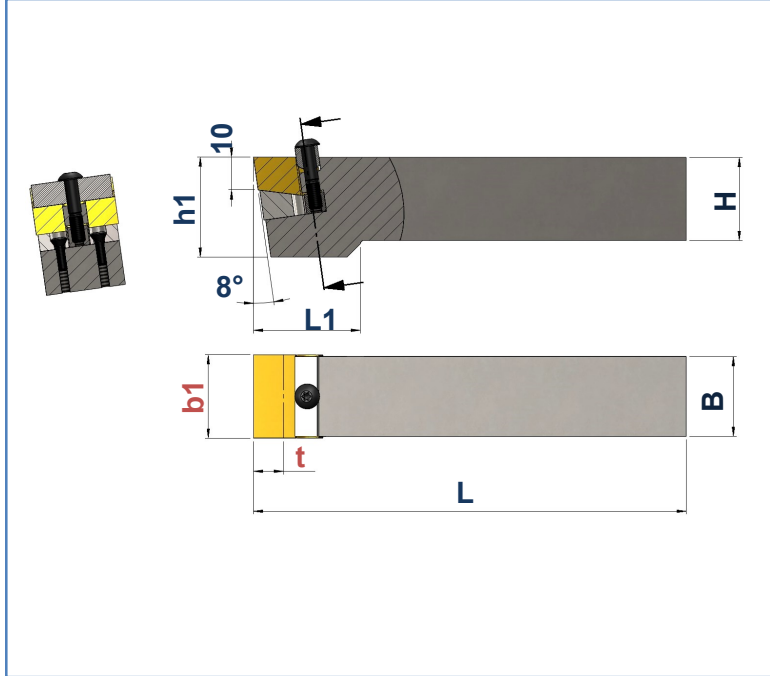

	Art. Nr. Item no. No. d'art.	Best. Nr. Ref. no. Réf.	Bezeichnung description désignation	B mm	H mm	b1 mm	h1 mm	L mm	L1 mm
1	108534	F-BFH-25-20-N	Halter / Basic tool holder / Porte-outil de base	24	20	25	30	130	32
	101256	F-BFH-25-25-N	Halter / Basic tool holder / Porte-outil de base	24	25	25	30	130	32
	108539	F-BFH-25-32-N	Halter / Basic tool holder / Porte-outil de base	24	32	25	32	130	-

	Art. Nr. Item no. No. d'art.	Best. Nr. Ref. no. Réf.	Bezeichnung description désignation	b1 mm	HM-Sorte Carbide grade Nuance de carbure
2	100674	BFP-25-FK	HM-Wechselplatten / Carbide inserts / Plaquettes échangeables	25	FK
	100677	BFP-25-K10			K10
3	101991	I-GP-25	Grundplatte/ Support blade / Plaque de base		
4	102099	KL-25	Klemme/Clamp/Mors de serrage		
5	101681	GS-4	Gewindestück / threaded bush / pièce filetée		
6	103429	SP-19 Torx T15	Spannschraube / Fixing screw / Vis de fixation		
7	107349	M3x8 T10	Spannschraube / Fixing screw / Vis de fixation		

F-BFH-30

max. Formtiefe: **t = 9 mm**
 max. depth of form: **t = 9 mm**
 max. profondeur de profil: **t = 9 mm**

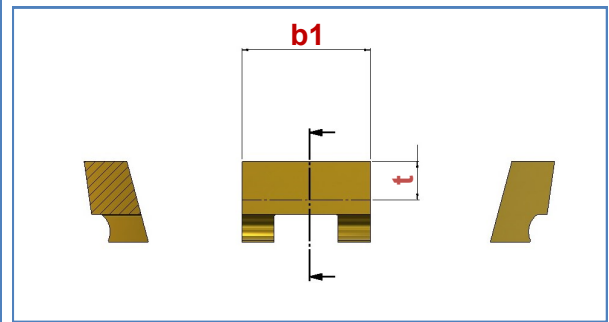
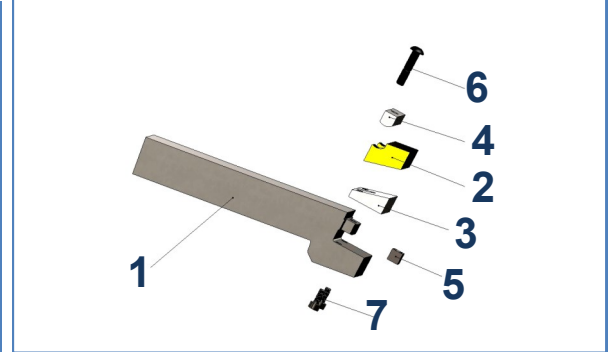
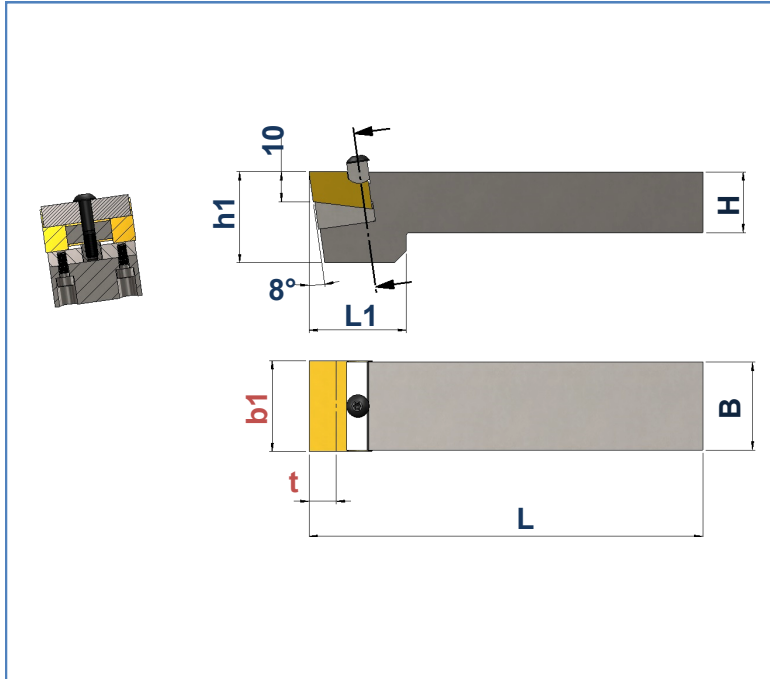

	Art. Nr. Item no. No. d'art.	Best. Nr. Ref. no. Réf.	Bezeichnung description désignation	B mm	H mm	b1 mm	h1 mm	L mm	L1 mm
1	101253	F-BFH-30-20-N	Halter / Basic tool holder / Porte-outil de base	29	20	30	30	130	32
	101257	F-BFH-30-25-N	Halter / Basic tool holder / Porte-outil de base	29	25	30	30	130	32

	Art. Nr. Item no. No. d'art.	Best. Nr. Ref. no. Réf.	Bezeichnung description désignation	b1 mm	HM-Sorte Carbide grade Nuance de carbure
2	100681	BFP-30-FK	HM-Wechselplatten / Carbide inserts / Plaquettes échangeables	30	FK
	100682	BFP-30-K10			K10
3	101664	GP-30	Grundplatte/ Support blade / Plaque de base		
4	102100	KL-30	Klemme/Clamp/Mors de serrage		
5	101681	GS-4	Gewindestück / threaded bush / pièce filetée		
6	103429	SP-19 Torx T15	Spannschraube / Fixing screw / Vis de fixation		
7	101115	M3x8 DIN912 SW2.5	Spannschraube / Fixing screw / Vis de fixation		

F-BFH-35

max. Formtiefe: **t = 9 mm**
 max. depth of form: **t = 9 mm**
 max. profondeur de profil: **t = 9 mm**

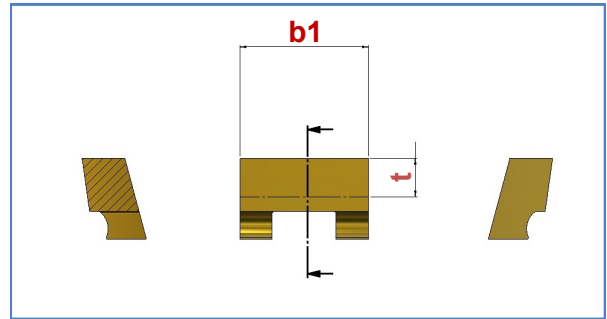
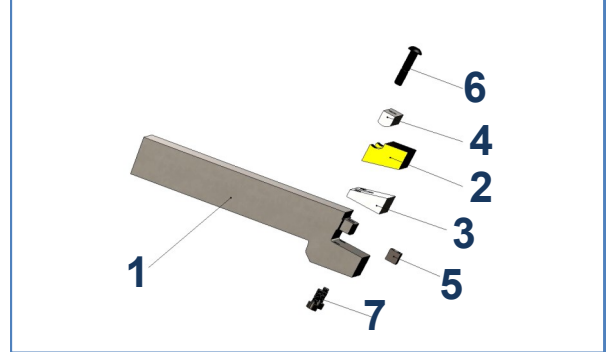
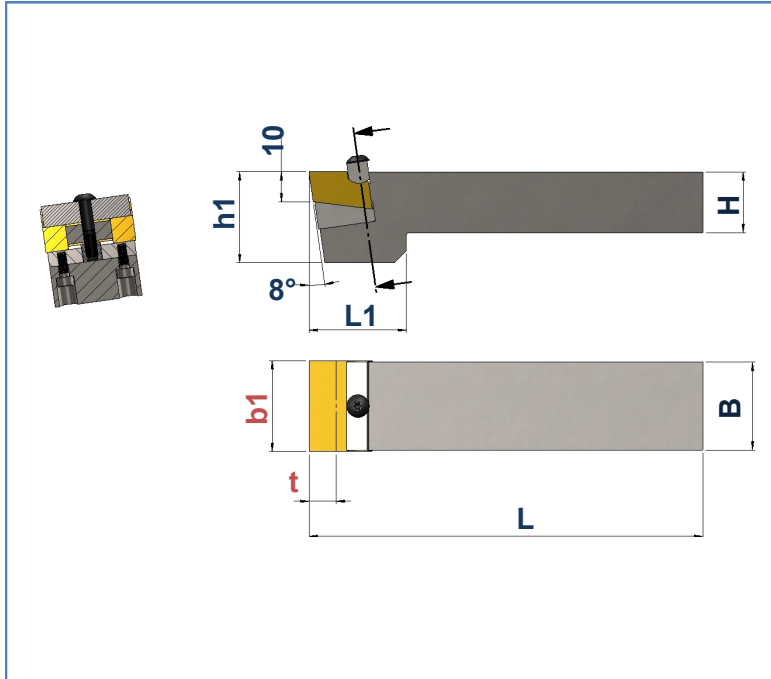

	Art. Nr. Item no. No. d'art.	Best. Nr. Ref. no. Réf.	Bezeichnung description désignation	B mm	H mm	b1 mm	h1 mm	L mm	L1 mm
1	108535	F-BFH-35-20-N	Halter / Basic tool holder / Porte-outil de base	34	20	35	30	130	32
	108536	F-BFH-35-25-N	Halter / Basic tool holder / Porte-outil de base	34	25	35	30	130	32
	108540	F-BFH-35-32-N	Halter / Basic tool holder / Porte-outil de base	34	32	35	32	130	-

	Art. Nr. Item no. No. d'art.	Best. Nr. Ref. no. Réf.	Bezeichnung description désignation	b1 mm	HM-Sorte Carbide grade Nuance de carbure
2	100685	BFP-35-FK	HM-Wechselplatten / Carbide inserts / Plaquettes échangeables	35	FK
	100687	BFP-35-K10			K10
3	101665	GP-35	Grundplatte/ Support blade / Plaque de base		
4	102101	KL-35	Klemme/Clamp/Mors de serrage		
5	101681	GS-4	Gewindestück / threaded bush / pièce filetée		
6	103429	SP-19 Torx T15	Spannschraube / Fixing screw / Vis de fixation		
7	101115	M3x8 DIN912 SW2.5	Spannschraube / Fixing screw / Vis de fixation		

F-BFH-40

max. Formtiefe: **t = 9 mm**
 max. depth of form: **t = 9 mm**
 max. profondeur de profil: **t = 9 mm**

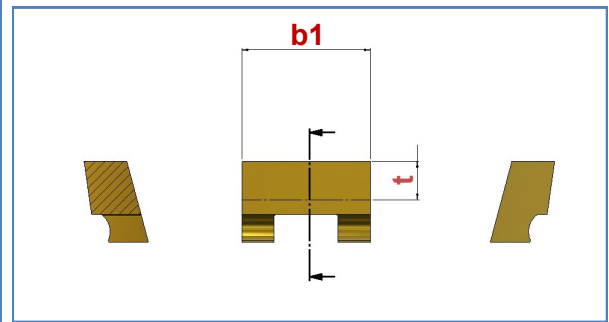
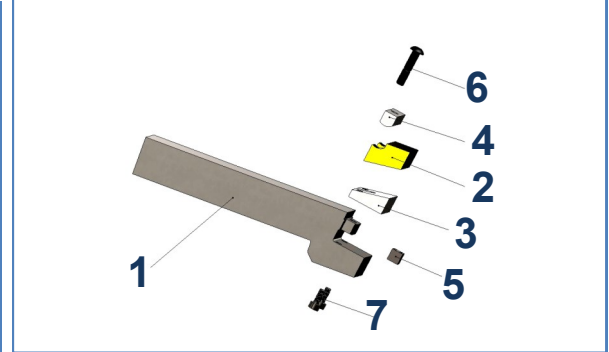
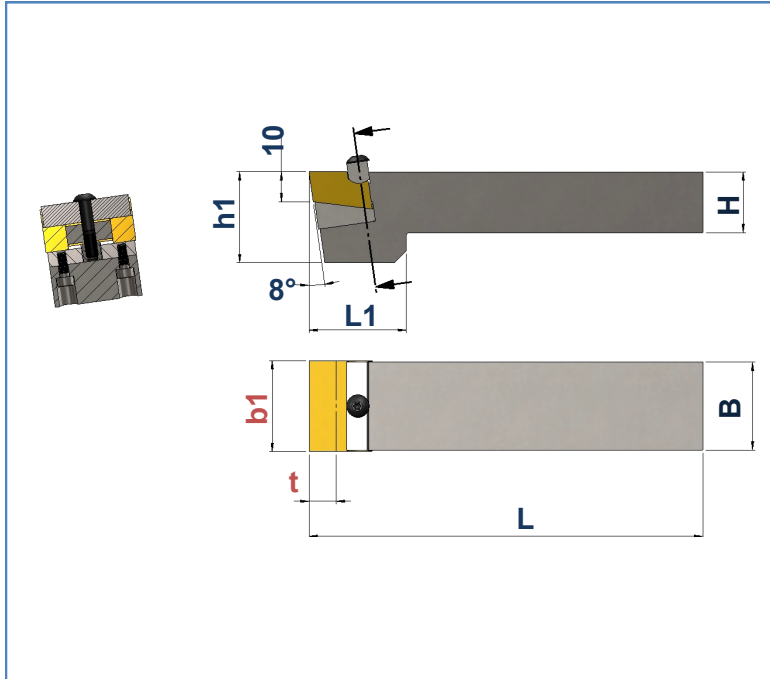

	Art. Nr. Item no. No. d'art.	Best. Nr. Ref. no. Réf.	Bezeichnung description désignation	B mm	H mm	b1 mm	h1 mm	L mm	L1 mm
1	101254	F-BFH-40-20-N	Halter / Basic tool holder / Porte-outil de base	39	20	40	30	130	32
	101258	F-BFH-40-25-N	Halter / Basic tool holder / Porte-outil de base	39	25	40	30	130	32

	Art. Nr. Item no. No. d'art.	Best. Nr. Ref. no. Réf.	Bezeichnung description désignation	b1 mm	HM-Sorte Carbide grade Nuance de carbure
2	100691	BFP-40-FK	HM-Wechselplatten / Carbide inserts / Plaquettes échangeables	40	FK
	100693	BFP-40-K10			K10
3	101666	GP-40	Grundplatte/ Support blade / Plaque de base		
4	102102	KL-40	Klemme/Clamp/Mors de serrage		
5	101681	GS-4	Gewindestück / threaded bush / pièce filetée		
6	103429	SP-19 Torx T15	Spannschraube / Fixing screw / Vis de fixation		
7	101115	M3x8 DIN912 SW2.5	Spannschraube / Fixing screw / Vis de fixation		

F-BFH-50

max. Formtiefe: **t = 9 mm**
 max. depth of form: **t = 9 mm**
 max. profondeur de profil: **t = 9 mm**

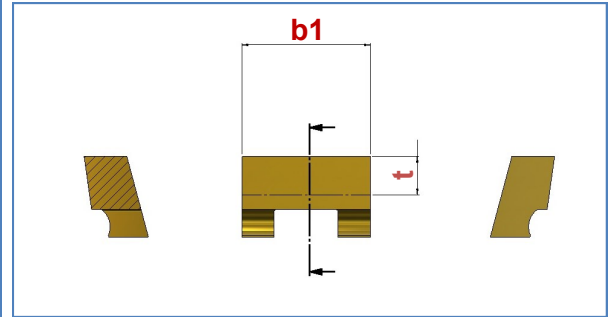
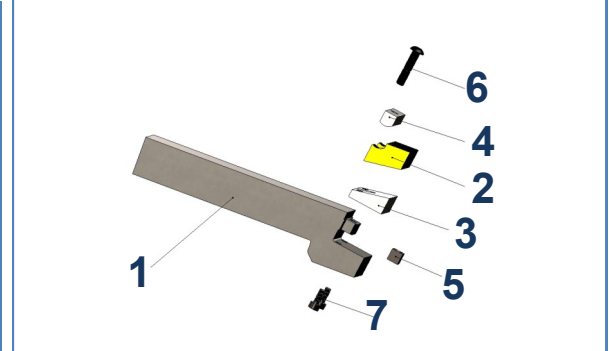
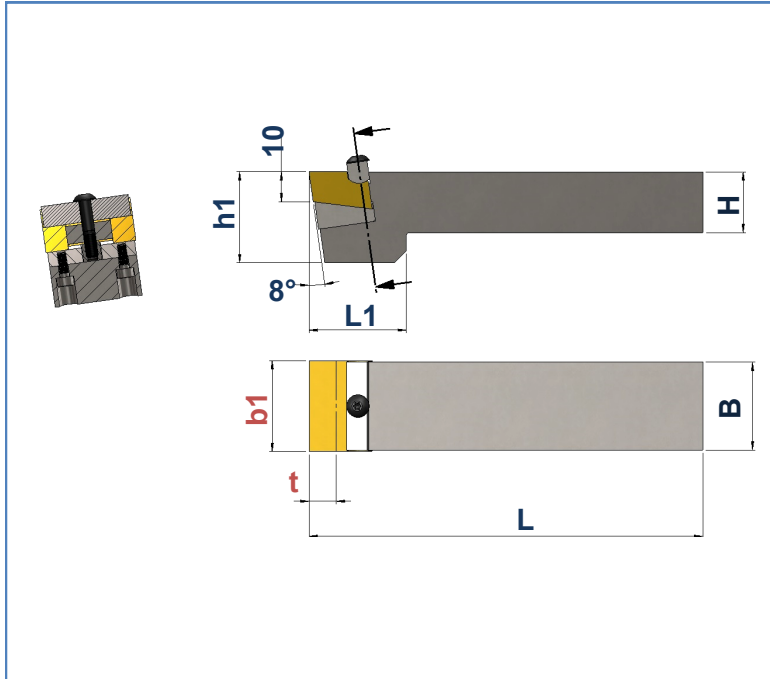

	Art. Nr. Item no. No. d'art.	Best. Nr. Ref. no. Réf.	Bezeichnung description désignation	B mm	H mm	b1 mm	h1 mm	L mm	L1 mm
1	108537	F-BFH-50-20-N	Halter / Basic tool holder / Porte-outil de base	49	20	50	30	130	32
	108538	F-BFH-50-25-N	Halter / Basic tool holder / Porte-outil de base	49	25	50	30	130	32

	Art. Nr. Item no. No. d'art.	Best. Nr. Ref. no. Réf.	Bezeichnung description désignation	b1 mm	HM-Sorte Carbide grade Nuance de carbure
2	100697	BFP-50-FK	HM-Wechselplatten/ Carbide inserts / Plaquettes échangeables	50	FK
	100698	BFP-50-K10			K10
3	101667	GP-50	Grundplatte/ Support blade / Plaque de base		
4	102103	KL-50	Klemme/Clamp/Mors de serrage		
5	101681	GS-4	Gewindestück / threaded bush / pièce filetée		
6	103429	SP-19 Torx T15	Spannschraube / Fixing screw / Vis de fixation		
7	101115	M3x8 DIN912 SW2.5	Spannschraube / Fixing screw / Vis de fixation		

SH-258-...

max. Formtiefe: **t = 6 mm**
 max. depth of form: **t = 6 mm**
 max. profondeur de profil: **t = 6 mm**

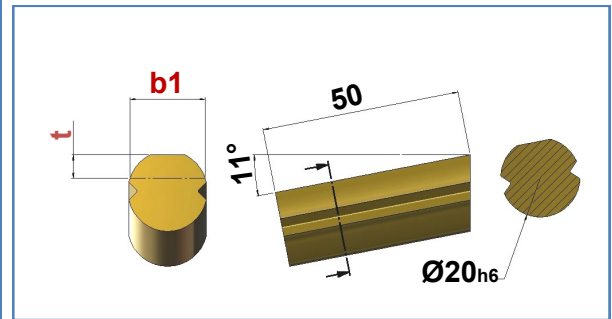
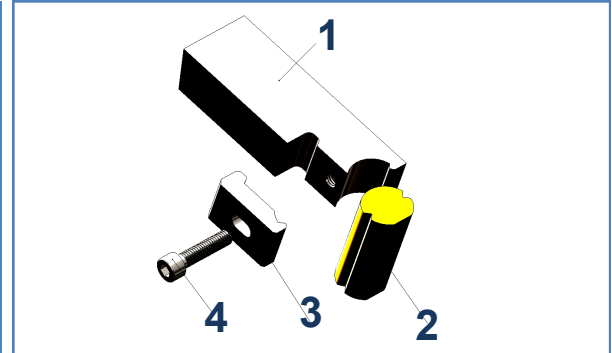
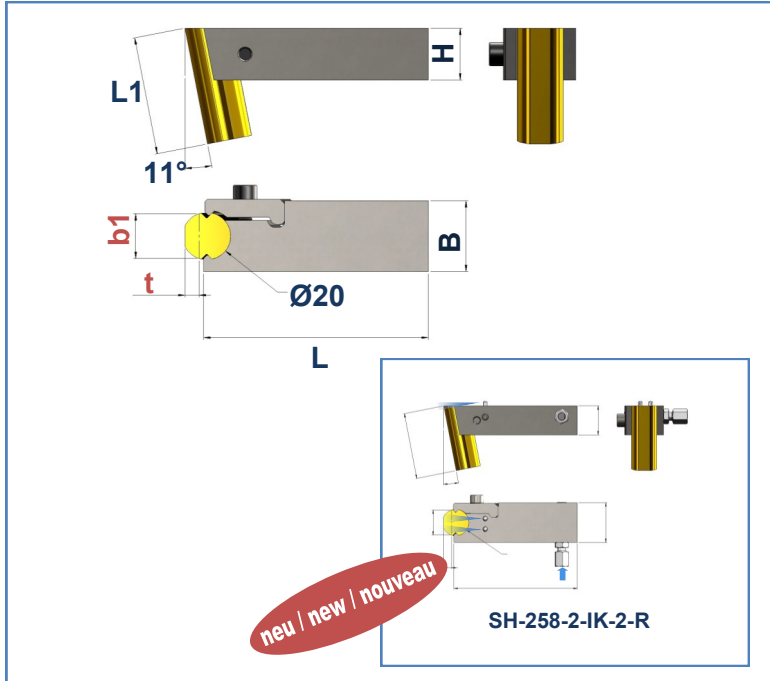

1	Art. Nr. Item no. No. d'art.	Bezeichnung description désignation	B mm	H mm	b1 mm	L mm	L1 mm
	108728	SH-258-1-R	Halter / Basic tool holder / Porte-outil de base	30	22	19	95
149002	SH-258-2-IK-2-R	Halter / Basic tool holder / Porte-outil de base	30	22	19	95	50

2	Art. Nr. Item no. No. d'art.	Best. Nr. Ref. no. Réf.	Bezeichnung description désignation	b1 mm	HM-Sorte Carbide grade Nuance de carbure
	103314	HF-SE-20-50-N-K20F	HM-Wechseleinsatz/ Carbide inserts / Plaquettes échangeables	19	FK

3	Art. Nr. Item no. No. d'art.	Best. Nr. Ref. no. Réf.	Bezeichnung description désignation
	108733	KL-258.1-R	Klemme/Clamp/Mors de serrage
4	108730	M6x16 DIN912 SW5	Spannschraube / Fixing screw / Vis de fixation

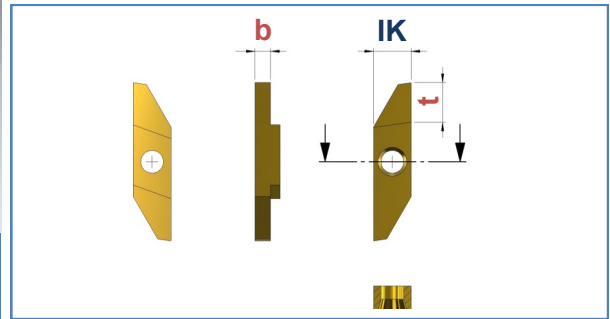
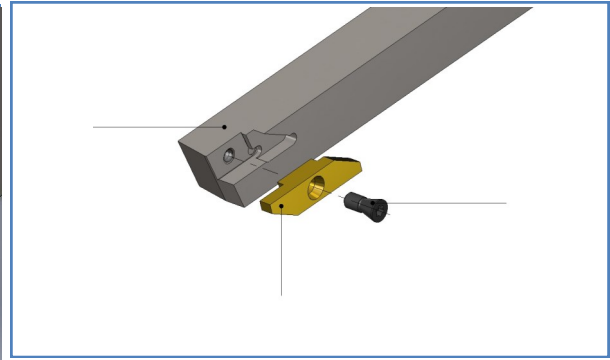
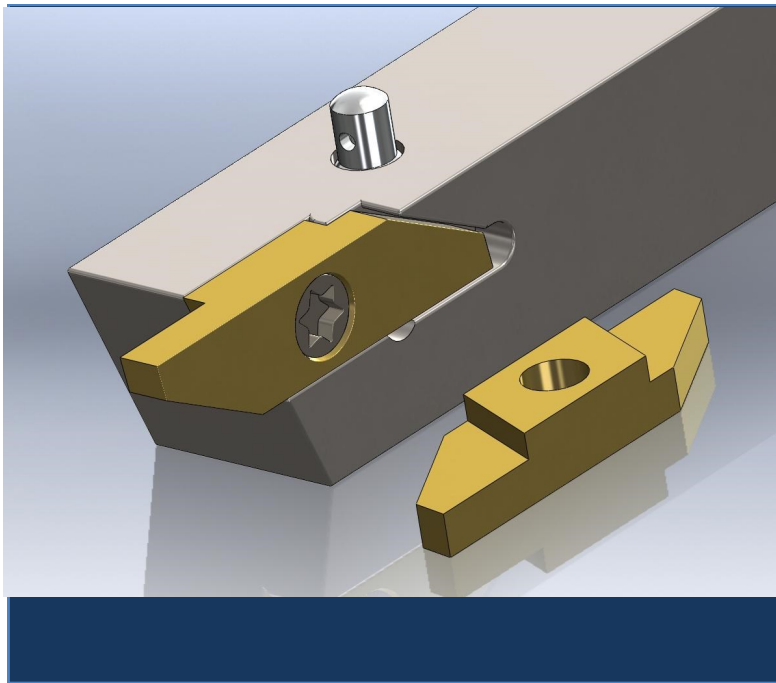

Weitere Informationen zu diesem System finden Sie im Katalog SSXA - verfügbar auf www.dieterle-tools.com unter „Drehwerkzeuge für Langdrehautomaten“

You will find further information regarding this system in our catalogue SSXA which is available at www.dieterle-tools.com under „Turning Tools for Sliding Head Machines“

Pour plus d'informations concernant ce système, reportez-vous au catalogue SSXA qui est disponible sur le site www.dieterle-tools.com dans la catégorie „Outils de tournage pour les tours automatiques“

System Système	t max. Formtiefe max. depth of form max. profondeur de profil	b max. Formbreite max. form width max. profondeur de profil	IK mm
SSXA-T06-...- L	6,2	2,5	6,0
SSXA-T06-...- R			
SSXA-06-...- L			
SSXA-06-...- R			
SSXA-T06-...-V-L			
SSXA-T06-...-V-R			
SSXA-F08-...-L	8,5	2,5	6,0
SSXA-F08-...-R			
SSXA-T08-...-L	10,0	3,5	8,0
SSXA-T08-...-R			

auch mit Innenkühlung / also with internal coolant supply / aussi avec arrosage central

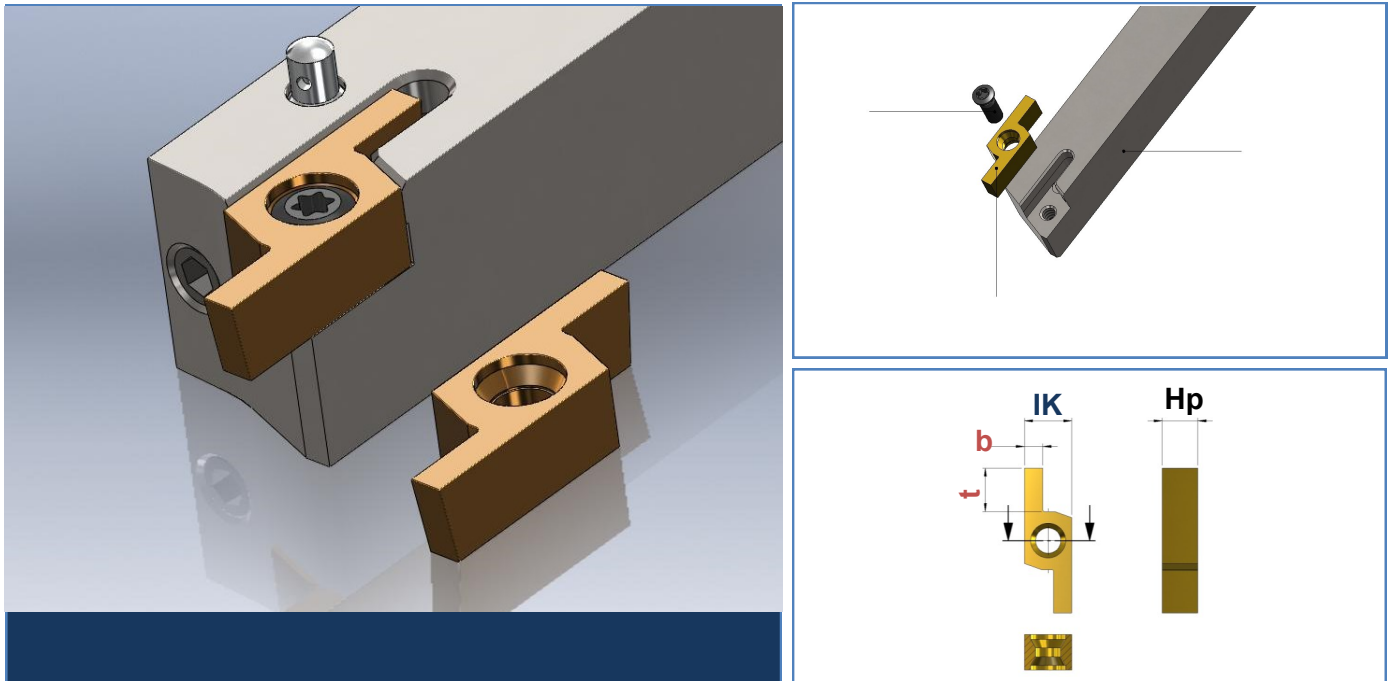

Weitere Informationen zu diesem System finden Sie im Katalog SSXC - verfügbar auf www.dieterle-tools.com unter „Drehwerkzeuge für Langdrehautomaten“

You will find further information regarding this system in our catalogue SSXC which is available at www.dieterle-tools.com under „Turning Tools for Sliding Head Machines“

Pour plus d'informations concernant ce système, reportez-vous au catalogue SSXC qui est disponible sur le site www.dieterle-tools.com dans la catégorie „Outils de tournage pour les tours automatiques“

System Système	t max. Formtiefe max. depth of form max. profondeur de profil	b max. Formbreite max. form width max. profondeur de profil	Hp mm	IK mm
SSXC-06-...-R SSXC-06-...-L	7,0	3,1	6,0	8,0
SSXC-08-...-R SSXC-08-...-L	9,0	4,1	8,0	8,0

auch mit Innenkühlung / also with internal coolant supply / aussi avec arrosage central

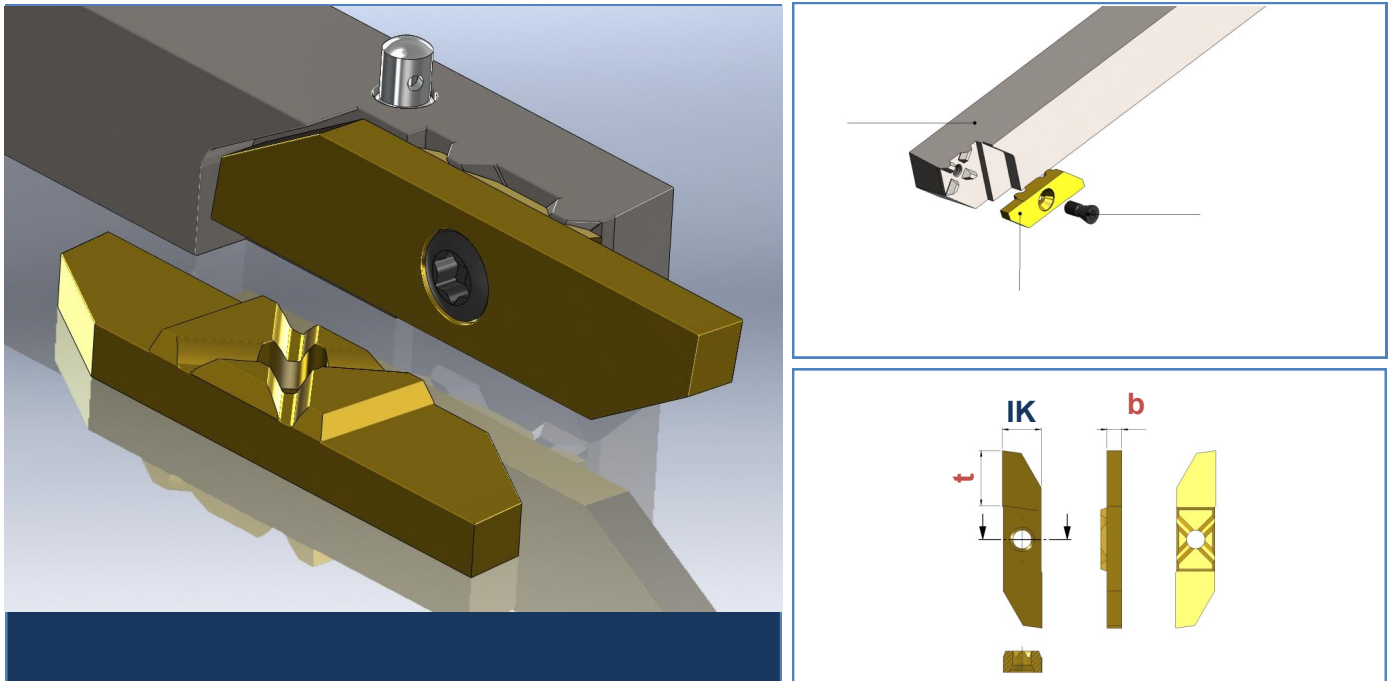

Weitere Informationen zu diesem System finden Sie im Katalog EcoStar - verfügbar auf www.dieterle-tools.com unter „Drehwerkzeuge für Langdrehautomaten“

You will find further information regarding this system in our catalogue EcoStar which is available at www.dieterle-tools.com under „Turning Tools for Sliding Head Machines“

Pour plus d'informations concernant ce système, reportez-vous au catalogue EcoStar qui est disponible sur le site www.dieterle-tools.com dans la catégorie „Outils de tournage pour les tours automatiques“

System Système	t max. Formtiefe max. depth of form	b max. Formbreite max. form width	IK mm
ES-T06-...-R ES-T06-...-L	5,2	2,5	7,4
ES-T13-...-R ES-T13-...-L	13,0	3,5	9,2

auch mit Innenkühlung / also with internal coolant supply / aussi avec arrosage central

Nachschleifvorrichtungen

Device for regrinding carbide inserts /
 Dispositif pour l'affutage des plaquettes en carbure

Nachschleifvorrichtung für HM-Wechselplatten System FPN12/16/20

Device for regrinding carbide inserts System FPN12/16/20

Dispositif pour l'affutage des plaquettes en carbure System FPN12/16/20

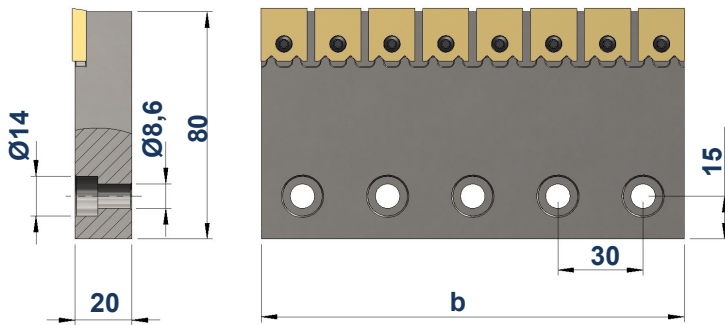

Art. Nr. Item no. No. d'art.	Best. Nr. Ref. no. Réf.	b mm	Für HM-Wechselplatten for carbide inserts pour plaquettes en carbure
108963	S-FPN-12	147	FPN-12
108964	S-FPN-16	149	FPN-16
108965	S-FPN-20	135	FPN-20

Nachschleifvorrichtung für HM-Wechselplatten System FP/EB

Device for regrinding carbide inserts System FP/EB

Dispositif pour l'affutage des plaquettes en carbure System FP/EB

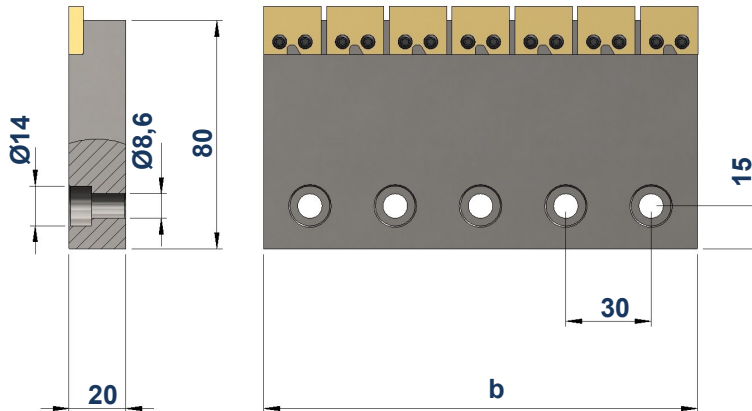

Art. Nr. Item no. No. d'art.	Best. Nr. Ref. no. Réf.	b mm	Für HM-Wechselplatten for carbide inserts pour plaquettes en carbure
164489	S-FP 11-13	152,5	FP-11 FP-11-5 FP-13 FP-13-5
164490	S-FP-EB 16-20	152,5	FP-16 FP20
164491	S-FP-EB 25-30	168	FP-25 FP-30

Nachschleifvorrichtung für HM-Wechselplatten BFP

Device for regrinding carbide inserts BFP

Dispositif pour l'affutage des plaquettes en carbure BFP

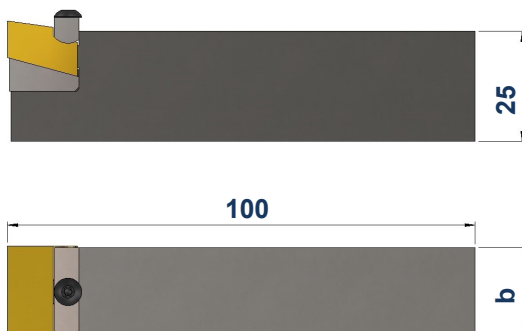

Art. Nr. Item no. No. d'art.	Best. Nr. Ref. no. Réf.	b mm	Für HM-Wechselplatten for carbide inserts pour plaquettes en carbure
102616	S-BFP-20/25-N	19	BFP-20
102617	S-BFP-30/35-N	29	BFP-30
102618	S-BFP-40/50-N	39	BFP-40

Innovatives Werkzeugsystem zur Zerspanung von Kunststoffen

Universal system for plastic machining



Bitte fordern Sie unsere Kataloge an !

Please ask for our catalogues!



Otto Dieterle Spezialwerkzeuge GmbH

Predigerstr. 56, 78628 Rottweil, Germany

Tel.: +49 (0) 741 94205-0 Fax: +49 (0) 741 94205-50 info@dieterle-tools.com

www.dieterle-tools.com

